

# INSTALLATION/OPERATION MANUAL

## HEAVY DUTY BATTERY CHARGERS

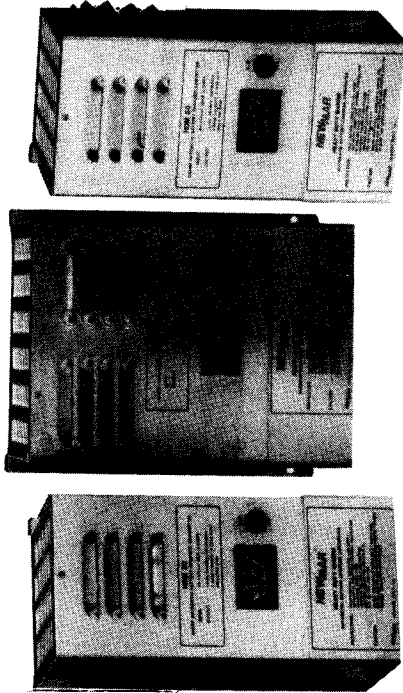

### Models:

HDM-30\*, 50, 70  
24-25, 24-35, 24-80  
220-12-40, 220-12-70  
220-24-20, 220-24-40, 220-24-80A



**ELECTRONIC POWER PRODUCTS**  
**COMMUNICATION ■ NAVIGATION**

USA  
P.O. Box 1306  
Newport Beach, CA 92663  
Shipping:  
2911 W. Garry Ave.,  
Santa Ana, CA 92704  
Phone: (714) 751-0488  
FAX: (714) 957-1621

#### NEWMAR LIMITED WARRANTY

Newmar warrants the original purchaser of this Battery Charger that it shall be free from defects in material and workmanship for a period of one (1) year from the date of original purchase.

In the event of failure caused by a defect in material or workmanship return to place of purchase or to NEWMAR, at either address on the front page. Please include proof of purchase, date of purchase and a written explanation of the alleged defect. If this product is determined to be defective by Newmar, Newmar will repair the product without charge. Any repairs or adjustments to be made on a defective product shall be determined by Newmar.

This warranty does not apply to products that have not been properly installed nor to products that have been damaged through accident, negligence, misuse, alteration, abuse or normal wear and tear. For proper installation have the authorized Newmar dealer install the product or an electronic technician of your choice may install the product by carefully following the directions provided at the time of purchase.

Newmar limits liability under this warranty to the repair of the product or reimbursement of the cost of the product to the consumer. This warranty does not cover postal and freight charges to return the product for repair.

For your own protection, check the product upon receipt for any damage sustained during shipping. Any such damage should be referred to the carrier.

No person, including any Newmar dealer is authorized to assume any further liability on behalf of Newmar beyond the warranty. Any purchaser should be referred exclusively to this warranty.

Newmar reserves the right to make changes in design and improvements on its products without assuming any obligations to install these improvements or otherwise modify any previously manufactured product.

There are no other warranties either express or implied that shall exist beyond the terms of this warranty.

Some states do not allow limitations on how long an implied warranty lasts, so the above limitation may not apply to you.

Some states do not allow the exclusion or limitation of incidental or consequential damages, so the above limitation or exclusion may not apply to you.

This warranty gives you specific legal rights, and you may also have other rights which vary from state to state.

**NEWMAR  
HEAVY DUTY BATTERY CHARGERS  
TABLE OF CONTENTS**

I) GENERAL INFORMATION .....	2
II) IMPORTANT SAFETY INSTRUCTIONS .....	3
III) INSTALLATION .....	6
IV) OPERATION AND MAINTENANCE .....	10
V) TROUBLESHOOTING .....	13
VI) FIELD SERVICE INFORMATION .....	14
VII) BATTERY CARE TIPS .....	17
VII) REFERENCE APPENDIX .....	19

## 1) GENERAL INFORMATION

Your NEWMAR battery charger is a solid state device engineered specifically to withstand the rigors of the harshest environmental conditions, and is especially designed to meet the greater power requirements of "live-aboard" and commercial vessels and vehicles.

These are some of the more important features of your battery charger.

- *Fully automatic operation* - The charger will respond automatically to battery demand, even under changing load conditions within the charger's rating, and maintain your batteries at full charge without overcharging.
- *Completely isolated outputs* - Three separate battery banks may be charged simultaneously, with each bank being charged according to individual demand. Isolation diodes prevent one battery bank from "bleeding" into another.
- *Wide input voltage range* - The charger will accept a wide input voltage range (85-140 VAC or 190-250 VAC depending on model) allowing operation of the charger in areas of low or high AC line voltage conditions.
- *Thermal protection* - An internal switch senses when the charger is overheating, due to high ambient temperatures or restricted air flow, and will shut the charger off until a safe operating temperature is restored, thus protecting vital components.
- *Isolation transformer* - The worry of dockline electrolysis through the charger is eliminated. Corrosion of through-hulls on the boat due to stray DC currents traveling through your AC line to the charger cannot occur, as the transformer utilized in the charger maintains complete isolation between input and output.
- *Current limit and self regulation* - The ferro-resonant design of the transformer is automatically current limiting, preventing damage to the charger due to over loads. In addition, the ferro-resonant circuit is inherently self-regulating so that the charger cannot exceed the rate output voltage, even should component failure occur. No adjustments are required.

- *Metering* - The total DC current output of your charger is easily monitored on a front panel mounted analog meter.
  - *Fuse Protection* - A front panel mounted AC input fuse will blow in the event that an internal short should develop within the charger.
  - *Reverse Polarity Protection* - An internal DC fuse protects the charger's output wiring from high battery current in the event of reverse polarity connection to the batteries or an internal short.
- In addition, your NEWMAR battery charger is warranted against any defects in materials or workmanship for one full year from time of purchase. Careful attention to these instructions should guarantee you years of trouble-free service.

## II) IMPORTANT SAFETY INSTRUCTIONS SAVE THESE INSTRUCTIONS

1. This manual contains important safety and operating instructions for the "HDM" series battery chargers.
2. Before using this battery charger, read all instructions and cautionary markings on (1) the battery charger (2) the battery, and (3) any product powered by the battery.
3. **CAUTION** - To reduce the risk of injury, charge only 6 cell lead-acid rechargeable batteries. Other types of batteries may burst, causing personal injury and damage.
4. Do no expose charger to rain or snow.
5. Use of an attachment not recommended or sold by NEWMAR may result in a risk of fire, electric shock or injury to persons.
6. To reduce the risk of damage to the electric plug and cord (if plugged into an AC outlet), pull by plug rather than cord when disconnecting the charger.
7. Make sure the cord is located so that it will not be stepped on, tripped over, or otherwise subjected to damage or stress.
8. An extension cord should not be used unless absolutely necessary. Use of an improper cord could result in a risk of fire and electric shock. If an extension cord must be used, make sure:
  - A. That pins on the plug of the extension cord are the same number, size and shape as those on the plug of the charger;
  - B. That the extension cord is properly wired and in good electrical condition;
  - C. That the wire size is large enough for the AC ampere rating of the HDM series charger. Use the SPECIFICATIONS CHART on page 16 to determine the full load input current of your HDM charger, then use the chart on the following page to determine the correct gauge wire for any extension cord used.

## RECOMMENDED MINIMUM AWG SIZE FOR EXTENSION CORDS FOR HDM BATTERY CHARGERS

AC Input Rating, Amperes	Length of Cord, Feet				
Equal to or greater than	but less than	25	50	100	150
AWG Size of Cord					
3	4	18	18	16	14
4	5	18	18	14	12
5	6	18	16	14	12
6	8	18	16	12	10
8	10	18	14	12	10
10	12	16	14	10	8
12	14	16	12	10	8
14	16	16	12	10	8
16	18	14	12	8	8
18	20	14	12	8	6

9. Do not operate the charger with a damaged cord or plug; replace it immediately.
10. Do not operate the charger if it has received a sharp blow, been dropped, or otherwise damaged; take it to a qualified serviceman.
11. Do not disassemble the charger; take it to a qualified serviceman when service or repair is necessary. Incorrect reassembly may result in a risk of electric shock and fire.
12. To reduce the risk of electric shock, disconnect the charger from AC source before attempting any maintenance or cleaning.

### WARNING -- RISK OF EXPLOSIVE GASES

1. WORKING IN THE VICINITY OF A LEAD-ACID BATTERY IS DANGEROUS. BATTERIES GENERATE EXPLOSIVE GASES DURING NORMAL BATTERY OPERATION. FOR THIS REASON, IT IS OF UTMOST IMPORTANCE THAT EACH TIME BEFORE USING YOUR CHARGER, YOU READ THIS MANUAL AND FOLLOW THE INSTRUCTIONS EXACTLY.
2. To reduce the risk of battery explosion, follow these instructions and those published by the battery manufacturer and by the manufacturer of any equipment you intend to use in the vicinity of the battery. Review cautionary markings on these products and on the engine.

## PERSONAL PRECAUTIONS

1. Someone should be within range of your voice or close enough to come to your aid when you work near a lead-acid battery.
2. Have plenty of fresh water and soap nearby in case battery acid contacts skin, clothing or eyes.
3. Wear complete eye protection and clothing protection. Avoid touching your eyes while working near a battery.
4. If battery acid contacts skin or clothing, wash immediately with soap and water. If battery acid enters the eye, immediately flood the eye with running cold water for at least 10 minutes and get medical attention immediately.
5. NEVER smoke or allow a spark or flame in the vicinity of the battery or engine.
6. Be extra cautious to reduce the risk of dropping a metal tool onto the battery. It might spark or short-circuit the battery or other electrical part and cause an explosion.
7. Remove personal metal items such as rings, bracelets, necklaces and watches when working with a lead-acid battery. A lead-acid battery can produce a short-circuit current high enough to weld a ring or the like to metal, causing a severe burn.
8. Use the battery charger for charging a 6 cell lead-acid battery only. It is not intended to supply power to a low voltage electrical system other than in a starter-motor application. Do not use the charger for charging dry-cell batteries that are commonly used with home appliances. These batteries may burst and cause injury to persons and damage to property.
9. NEVER charge a frozen battery.

## PREPARING TO CHARGE

1. Be sure the area around the battery is well ventilated.
2. Clean battery terminals. Be careful to keep corrosion from coming in contact with eyes.
3. Add distilled water in each cell until battery acid reaches level specified by battery manufacturer. This helps purge excessive gas from cells. Do not overfill. For a battery without cell caps carefully follow manufacturer's recharging instructions.
4. Study all battery manufacturer's specific precautions such as removing or not removing cell caps while charging and recommended rates of charge.

## GROUNDING AND AC POWER CORD CONNECTION

1. The charger should be grounded to reduce the risk of electric shock.

2. 80-140 VAC input charger models are provided with an AC power cord with a grounding pin for use with a standard AC outlet. This plug must be plugged into an outlet that is properly installed and grounded in accordance with all local codes and ordinances.

**DANGER:** Never alter the AC cord or plug provided. If it will not fit the outlet, have a proper outlet installed by a qualified electrician. Improper connection can result in a risk of electric shock.

3. If the charger is to be hard-wired it should be connected to a grounded metal permanent wiring system; or an equipment grounding conductor should be run with circuit conductors and connected to the equipment grounding lead on the battery charger. Connections to the battery charger should comply with all local ordinances.

### **External connections to the charger shall comply with the United States Coast Guard Electrical Regulations (33CFR183, Sub-Part 1).**

## **III) INSTALLATION**

**A) Materials:** Your HDM series battery charger comes with the following materials: (4) ring lug crimp connectors (5 connectors with 4 bank models; 3 connectors with 2 bank models), (3) wire splices, (1) strain relief, (1) drip shield, (1) Customer Satisfaction/Warranty card, and (1) installation/Operation Manual.

Check to see that these have been included with the packaging. If any item is missing, please contact the factory.

**(B) Location:** The battery charger should be mounted on a bulkhead or other suitable mounting surface as close to the batteries to be charged as possible. The area should be well ventilated and free from excessive moisture, exhaust manifolds and battery fumes. Vertical mounting will facilitate cooler operation but horizontal mounting is acceptable when this is impossible. A minimum of 6" space above and below the unit is recommended for adequate ventilation. A thermal switch within the charger will cycle the unit on and off if the temperature is too great. If this thermal cycling is noted, the charger should be relocated.

**C) Mounting:** You will require (4) 1/4" (6 mm.) screws with washers to mount the charger. Note that there is a slot in each mounting flange which is "keyhole" shaped. This is provided to ease vertical installation. Make a mark on the bulkhead where each of the keyhole slots will be located. Then drive a screw about half-way in at each of these marks. Hang the charger onto the bulkhead using the "keyhole" slots. This will save you having to support the charger's weight while you are driving in the permanent mounting screws. Note: The "keyhole" slot is not to be used as a permanent mounting point.

If you wish to determine prior to installation whether you have adequate mounting space, check the case dimensions in the SPECIFICATIONS table on page 7. Use the table on the next page to determine the center-to-center distance between corner mounting holes.

### **Mounting Hole Table - Distance Between Corner Mounting Holes**

<b>Model</b>	<b>Horiz. Distance</b>	<b>Vert. Distance</b>
HDM 30, 50, 24-25, 220/12-40, 220/24-20	6.68", 16.97cm	6.96", 17.68cm
HDM 70, 24-35, 220/12-70, 220/24-40	9.79", 24.87cm	9.80", 24.89cm
HDM 24-80, 220/24-80A	9.50", 24.13cm	18.50", 46.99cm

**D) Drip Shield Installation:** A drip shield has been provided with your charger to prevent any moisture from dripping down into the unit through the cooling vents. To install the drip shield:

- 1) Loosen the two top mounting bolts slightly. Slide the slotted rear legs of the drip shield over the mounting screws on the forward side of the flange. Tighten the screws.
- 2) Loosen the two screws on either side of the charger at top center. Swing the slotted forward legs of the drip shield down and seat them on each screw. Tighten the screws.

**FIGURE 1: DRIP SHIELD INSTALLATION**

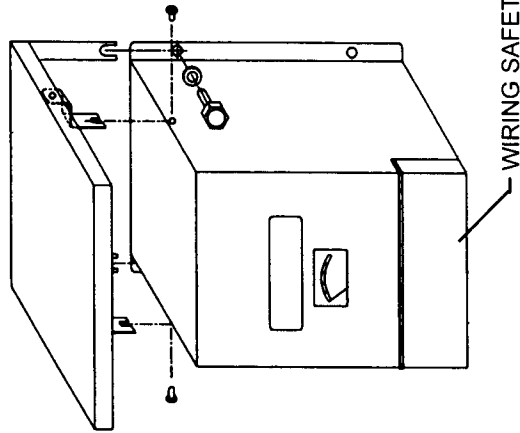

### E) DC Output Wiring:

Loosen the two screws located at the top front of the wiring safety cover (see FIGURE 1). Remove the cover. This will expose both the DC output terminals and the AC input wires.

Using the ring lug connectors provided, attach your DC wires to the output terminals of the charger. The DC wire size table below may be used to determine the correct gauge wire, based on the model you have and the distance from the charger to the batteries. Wire size will depend on the amount of current the charger is designed to deliver, and is unrelated to input or output voltage.

**DC Wire Size Table:**

Model	Distance from Batteries	Wire Gauge (AWG)
15, 20, 25, 30 amp	5'	#10
35, 40, 50 amp	10'	#8
70, 80 amp	15'	#6
	20'	#6

Run your wires as directly as possible to the posts of the batteries to be charged. Ensure that your connections are tight and that correct polarity is carefully observed at all times. The battery posts should be free of any rust or corrosion.

**IMPORTANT NOTE: EVEN MOMENTARY REVERSE POLARITY CONNECTION MAY SEVERELY DAMAGE YOUR CHARGER. THE POSITIVE (+) TERMINAL MUST BE WIRED TO THE POSITIVE POST OF THE BATTERY AND THE NEGATIVE OR COMMON (-) TERMINAL TO THE NEGATIVE POST OF THE BATTERY OR COMMON BUS.**

When one or more of the available charger banks is not needed, (if, for instance, you have only two battery banks and yours is a three bank charger) it is not necessary to jumper the output of that bank onto one of the others. Nor will you get additional charging by running a second wire from the extra bank to your load. The charger is able to deliver its full rated output through a single bank, if necessary.

It is recommended that DC wiring from the charger to the batteries be as direct as possible. Line voltage loss, contamination of electronic noise and other annoyances are possible if the charging leads are routed through a central electrical distribution panel. Any elaborate configurations are best left to the qualified boat electrician.

Two common DC wiring configurations are illustrated in FIGURES 2 and 3.

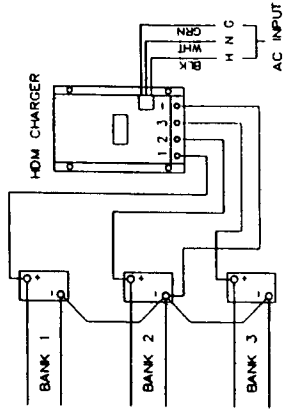

**FIGURE 2: SIMPLE DC WIRING**

**FIGURE 3: WIRING WITH BATTERY SWITCH**

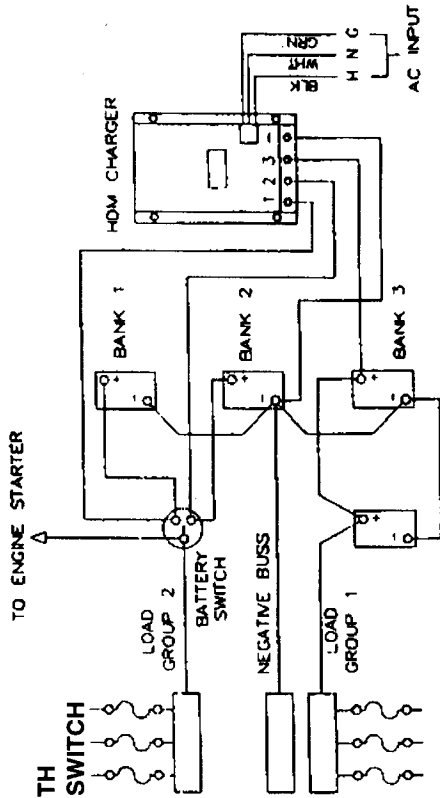

F) **AC Input Wiring:** Your charger should be wired to a separate dedicated fuse or circuit breaker on an AC distribution panel. Use the Panel Breaker Table below to determine the recommended fuse or breaker value:

**Panel Breaker Table:**

Model	Breaker or Fuse Value
HDM 30, 50, 24-25,	10 amp
220-12-40, 220-12-70,	15 amp
220-24-20, 220-24-40	20 amp
HDM 70, 24-35	35 amp
HDM 220-24-80A	20 amp
HDM 24/80	230 VAC: 20 amp

For all models AC input wiring should be stranded 3 conductor type. Use 16 AWG wire for those models in the table above which are minimum - fused at 10 amps. 14 AWG wire is recommended for all other models. Verify that your wires are disconnected from shore power or any other AC power source before proceeding.

**Note:** Because the HDM charger is designed for permanent installation, it will typically be hard-wired from your AC system. However, 115 VAC input models are provided with an AC cord with molded three-pin plug, should you desire to use one. **220 VAC NOTE (HDM 24-80 ONLY):** If AC input is derived from a 220-240 VAC source with two Hot leads, an external fuse or circuit breaker must be used to protect the unfused (normally Neutral, now Hot) AC input.

Locate and carefully pull out the exposed ends of the three wires in the compartment directly above the DC outputs. These are your AC input leads.

Install the provided strain-relief. Simply snap it into the hole on the right side of the charger and ensure that it has locked into place.

Feed the AC wiring coming from the distribution panel through the strain-relief out to where you can work easily with the exposed leads. Carefully observing color coding, splice the AC wiring to the charger input leads using the crimp connectors provided.

- Black ..... AC Hot (fused)
- White ..... AC Neutral
- Green ..... AC Ground (safety, earth)

Ensure that there is no exposed bare wiring around the splices and gently push the connected wires back into the AC compartment. Tighten the screw on the strain-relief until it grips the input wiring snugly. Do not overtighten. Replace the safety cover.

Note: All charger wiring should be in accordance with Coast Guard and A.B.Y.C. recommendations. For information governing these see the REFERENCE APPENDIX at the end of this manual.

## IV) OPERATION

### Start Up

Before powering up your charger, disconnect any DC loads to the batteries. Apply AC power. Observe the DC ammeter on the front of the charger. This should give some indication of the state of charge of your batteries. If the meter is reading mid-scale or higher, it is an indication that the batteries are in a relatively low state of charge. The charging current to each battery bank will be determined by that bank's state of charge. This is directly related to open circuit battery voltage. Relatively low battery voltage is indicated by the higher output of the charger.

Note: The HDM battery charger is self-limiting and will rarely blow an input fuse, even under extreme load conditions. If the input fuse should blow upon first application of power, disconnect AC power to the charger and consult the TROUBLESHOOTING section of this manual.

When the meter needle returns to bottom-scale, this is an indication that your batteries are at or nearing full charge. If you have wet lead-acid batteries, you may use a hydrometer to check battery condition, however, bear in mind that specific gravity will lag behind measured voltage when charging. A hydrometer check when the meter needle first reaches bottom-scale may reveal that the batteries are only at charge, which the charger automatically provides, in order to reach 100% of full charge and the desired specific gravity.

When there is no load on your batteries the charger will bring them to a finishing voltage of approximately 14.0 VDC for 12 volt systems or 28.0 VDC for 24 volt systems, and "float" them there. The amount of time it takes to fully charge your batteries will depend on their relative state of discharge, as well as battery bank capacity. If the charger is properly matched to your battery system and you are certain there is no DC load upon it, recharge time, even for deeply discharged batteries will rarely exceed 72 hours. If after this length of time the charger's output has failed to fall below 3 amps, disconnect the charger and consult the TROUBLE SHOOTING section of this manual. **Note: Batteries which have been allowed to remain in a deeply discharged condition for a long period of time may be unable to accept or hold a charge.**

The graph in FIGURE 4 illustrates how the output of the charger is directly related to rising battery voltage as charging takes place. The charging curves of several models are illustrated here as examples:

FIGURE 4: CHARGER OUTPUT CHARACTERISTICS

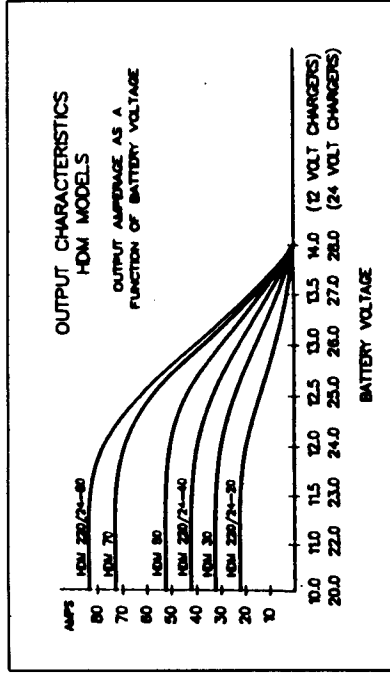

Apply a load to the charger by switching on some lights, a pump or some other DC appliance. Observe the charger meter. You will note that the output of the charger is roughly equivalent to the expected current draw of the appliance. As current is drawn from the battery, battery voltage is lowered. The charger will respond to the lower voltage on that bank with a higher output.

### Normal Operation

In order to insure that you receive maximum satisfaction with the performance of your charger, it is a good idea to have some understanding of its characteristics and intended applications.

#### • Recharge Time

Your NEWMAR charger has been designed for applications where there is a more or less constant demand for DC power and it is designed to deliver high amounts of DC current over long periods of time as the load demands. The ferro-resonant transformer used in the charger is inherently self-limiting in output current when demand reaches the upper limit of the charger's rating. This allows the charger to protect itself against overloads. Since overloads are the primary cause of component failure, this feature insures long life and reliable service.

While the charger is protected against overloads and is able to handle constant current demand, the ferro-resonant design does require a lengthier recharge time than other so-called "brute force" or quick-recovery chargers for batteries which are deeply discharged. For this reason it is recommended that the charger be left on whenever there is a DC load on your battery system and there is AC power available to the charger. This will maintain batteries at peak voltage and shorten recharge time after they have been used with no charging source available.

- Constant vs Occasional Use

Although the charger is intended primarily to meet the demands required on "live-aboard" and commercial vessels, it is understood that it will sometimes be used also by boat owners whose boat use is more recreational and occasional. If the boat is to be left for long periods of time with no load upon the DC system, it is recommended that the battery water level be checked at least once a month. (This does not apply to "maintenance-free" batteries.)

- Use with Generator

When powering your charger with an AC generator, it is important to pay careful attention to the input frequency specified. (See SPECIFICATIONS chart on page 16.) While the charger will accept a wide input voltage range, the input frequency must be no more than 1 cycle below or 3 cycles above the specification. Beyond that range the transformer in the unit may begin to overheat and go into thermal cycling or the charge rate may be adversely affected. Ensure that the proper output frequency is attained before applying generator power to the charger.

Some generators may produce a distorted sine wave, unlike that which is supplied by shore power. In that case, a reduction in charger performance may be encountered when switching from shore power to ship's power.

- Operation with Engine

It is perfectly acceptable to leave the charger connected and operating when starting the engine and while it is running. Output diodes will protect the charger from any harm from the alternator. As the alternator or generator charges the batteries, the charger output will decrease. When battery voltage finally exceeds the float voltage of the charger, the charger will simply shut off. It will remain off until battery voltage falls below that float voltage, at which point the charger will automatically return to service.

When starting your engines, the charger will provide an extra "boost". The self-limiting aspect of the charger insures that you will not harm the internal circuitry or blow input fuses when the starter demands an initial current surge from the battery.

- Operating Temperature

It is normal for the charger to remain very warm to the touch, even under no-load conditions. But it can not dangerously overheat, even under high loads, when operating in normal ambient temperature conditions (Temperature Rating: -18-50°C).

In a high temperature environment, such as may be encountered in engine rooms, etc., a thermal switch mounted within the transformer will automatically shut the unit down if the temperature rise is excessive, then will automatically return the unit to service when normal operating temperature is reached. If this thermal cycling is noted, the charger must be relocated to where it will receive

a greater flow of cooling air. Continued thermal cycling will greatly shorten the life of the charger.

- Operation With No Battery Connected

It is normal on some models to measure low or high voltage across the HDM's output terminals when there is no battery connected. Also, some models may produce a "motorboating" sound when the charger is turned on with no battery connected. This is a normal reaction of the ferro-resonant transformer and does not indicate a problem with the charger.

## V) TROUBLESHOOTING

### PROBLEM

A. Batteries are showing greater than normal water loss.

B. Batteries not coming up in charge.

C. Charger continues to charge at 3 amps or more - does not taper back in charge.

D. Charger does not charge.

### POSSIBLE CAUSE

Charger is left on for several weeks without any draw on battery system.

Extremely discharged batteries requiring long recharge time.

1. DC load still connected to batteries.

2. Bad cell in one of the batteries to which the charger is connected.

1. Blown input fuse.

2. Charger is not receiving AC input voltage.

### SOLUTION

Turn charger off when there is no activity on vessel for extended periods or leave a small draw on battery system such as one or two DC lights.

Turn off all DC loads and allow charger 24-72 hours to recharge batteries. Note: Please refer to output characteristics charts on page 11.

1. Turn off main battery switch to DC electrical panel or turn off all DC loads.

2. Check for shorted cell in all wet lead-acid batteries using a hydrometer. Replace battery if cell is shorted. Refer to manufacturer for testing maintenance-free batteries.

1. Replace fuse with another of correct value.

2. Using a voltmeter, confirm charger is receiving AC input voltage, check input connections.

FIGURE 5. SCHEMATIC DIAGRAMS

A) All models except HDM 24-25, 24-35 and 220/24-20

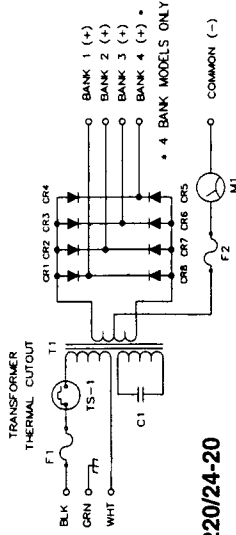

B) HDM 24-25, 24-35, 220/24-20

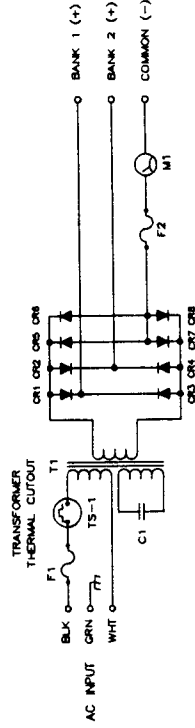

The manufacturer's part numbers or description and the schematic references for their location in the circuit are listed in the PARTS TABLES.

PARTS TABLES  
12 Volt Models

Schematic Ref.	MODEL NUMBER				
	HDM-30	HDM-50	HDM-70	HDM 220/12-40	HDM 220/12-70
F1	8 Amp Fast Blo	10 Amp Fast Blo	15 Amp Fast Blo	5 Amp Fast Blo	10 Amp Fast Blo
T1	xImr. #11407	xImr. #11412	xImr. #11426	xImr. #11419	xImr. #12655
F2	HBO-100 Amp	HBO-150 Amp	HBO-150 Amp	HBO-150 Amp	HBO-150 Amp
M1	0-30A Emico	0-50A Emico	0-75A Emico	0-50A Emico	0-75A Emico
CR1-CR8	1N1186AR	1N1186AR	1N1186AR	1N1186AR	1N1186AR
C1	7mfd./660 VAC	8mfd./660 VAC	10mfd./660 VAC	12mfd./660 VAC	6mfd./660 VAC

24 Volt Models

Schematic Ref.	MODEL NUMBER				
	HDM 24-80	HDM 24-35	HDM 24-25	HDM 220/24-20	HDM 220/24-40
F1	AGU-20/35	15 Amp Fast Blo	10 Amp Fast Blo	5 Amp Fast Blo	10 Amp Fast Blo
T1	xImr. #12977	xImr. #11426	xImr. #11412	xImr. #11419	xImr. #12802
F2	HBO-150 Amp	HBO-100 Amp	HBO-100 Amp	HBO-100 Amp	HBO-150 Amp
M1	100-A. Modules 2-1/2" w/Shunt	0-50A Emico	0-30A Emico	0-30A Emico	0-100A. Modules 2-1/2" w/Shunt
CR1-CR4	MSIS30610	1N1186AR	1N1186AR	1N1186AR	MSIS30610
CR5-CR8	MSIS30610	1N1186A	1N1186A	1N1186AR	MSIS30610
C1	10mfd./660 VAC	10mfd./660 VAC	8mfd./660 VAC	12mfd./660 VAC	10mfd./660 VAC

3. Charger output is not connected to batteries.
4. Defective charger.

Internal short

E. Charger repeatedly blows input fuse with no batteries.

F. Reverse polarity Connection to charger has caused charger to stop charging.

G. Low output voltage measured across charger output terminals.

H. Model HDM 220/24-80A hums and draws several amps of AC current with no batteries attached.

## VI) FIELD SERVICE INFORMATION

Important Note:

Information provided in this section is intended solely as an aid to qualified field service technicians. Any repair performed by someone other than a qualified electronic technician which results in damage to the charger or auxiliary equipment shall void all warranties and release Newmar from any liability.

**Component Replacement**

Replacement components for the charger can be ordered from the factory when they have been determined by the field technician to be defective and in need of replacement. Using the schematic diagrams provided in FIGURE 5, the location of the component in the circuitry may be determined and the schematic reference used when ordering.

Same as above.

Same as above.

Check charging leads from charger to batteries.

With charger off, connect charging leads from charger to batteries.



# VII) BATTERY CARE TIPS

Regular maintenance and proper care will assure you of reliable service from the most depended upon and sometimes most neglected items, your batteries and battery charger. NEWMAR battery chargers are designed to keep your batteries fully charged but your batteries also need proper regular maintenance to provide a maximum life of service.

**ALWAYS READ AND FOLLOW THE BATTERY MANUFACTURER'S INSTRUCTIONS.**

## Battery Installation

Batteries must be securely mounted to prevent them from falling over when the vehicle or boat is in motion. A loose battery can do serious damage. Batteries should be mounted in a battery box to contain any acid spill. Batteries give off a certain amount of hydrogen gas when they are charging. When concentrated, this gas is highly explosive. Therefore make sure they are in an accessible place with adequate ventilation for any hydrogen gas discharge.

## Cleaning Batteries

Dirt and electrolyte salts can build up on the top of your batteries. This accumulation conducts electricity stored in the battery and can cause the battery to discharge by itself. Therefore, at least twice a year, it is a good idea to disconnect the battery cables and scrub the battery with a baking soda solution. Rinse with fresh water and dry with a clean cloth.

You may wish to purchase a set of terminal post corrosion prevention rings. These are alkali-saturated felt rings that slip over the battery post to reduce corrosion. Do not apply grease to any part of the battery terminals, but you may use an occasional light spray of silicone lubricant.

## Routine Checks and Maintenance

Batteries should periodically be "exercised" (slowly discharged and then recharged) to keep them in top condition. New batteries may need to be exercised before they will be capable of their full rating.

If your batteries are not the sealed type, water should be added to them whenever needed. The electrolyte should cover the plates by about 1/2", allowing a small air space at the top. Do not fill the cells up to the filler cap as this could cause the battery to sputter out electrolyte when it is being charged. Only distilled water should be used - never plain tap water. Tap water contains chemicals and elements that can alter the properties of the electrolyte, including specific gravity. Some chemicals may also create an insulating coating on the battery plates which will retard current flow.

The chart below may be used as a handy reference for all HDM series chargers regarding performance specifications and physical characteristics:

## SPECIFICATIONS

MODEL	INPUT		OUTPUT		CASE SIZE REF.	WEIGHT	
	REF. AMPS @ Full Load	Volts	Banks	Amps.		LBS.	KG.
HDM 30	B	5.5	3	30	B-8	28	12.7
HDM 50	B	8.6	3	50	B-8	30	13.6
HDM 70	B	11	4	70	B-9	45	20.5
HDM 24-25	B	8.6	2	25	B-8	30	13.6
HDM 24-35	B	11	2	35	B-9	45	20.5
HDM 24-80	D	32/16	4	80	B-10	85	38.6
HDM 220-12-40	C	3	3	40	B-8	28	12.7
HDM 220-12-70	C	8	4	70	B-9	40	18.2
HDM 220-24-20	C	3	2	20	B-8	28	12.7
HDM 220-24-40	C	8	4	40	B-9	55	25.0
HDM 220-24-80A	C	16	4	80	B-10	85	38.6

## INPUT RATINGS

REF.	VOLTAGE	FREQUENCY
B	80-140 VAC	60 HZ
C	190-250 VAC	50 HZ
D	80-140/190-250 VAC	60 HZ

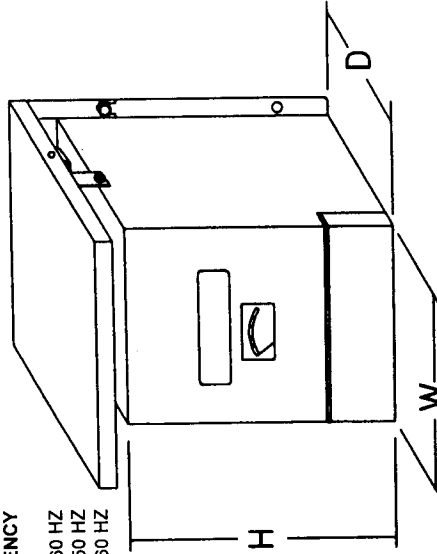

## CHARGER CHARACTERISTICS

DUTY CYCLE RATINGS	TEMP RATING	FLOAT VOLTAGE
Continuous @ 12.0 VDC or 24.0 VDC	-18-50°C	14.0 - 12 Volt System 28.0 - 24 Volt System

## Dimensions

Size	Inches		
	H	W	D
B-8	11.9	7.38	7.8
B-9	11.9	10.5	7.8
B-10	19.5	10.5	9.75
(Centimeters)			
B-8	30.2	18.8	19.8
B-9	30.2	26.7	19.8
B-10	49.5	26.7	24.8

# VIII) REFERENCE APPENDIX

For more information about boat wiring to conform to U.S. Coast Guard regulations, write to:

Superintendent of Documents  
 Government Printing Office  
 Washington, D.C. 20402

REQUEST: 33 CFR 183 Subpart 1

For information about American Boat and Yacht Council recommendations for boat wiring, write to:

American Boat & Yacht Council  
 3069 Soloman's Island Road  
 Edgewater, MD 21037

REQUEST: Standards & Recommended Practices for Small Craft  
 AC Systems - Section E8  
 DC Systems - Section E9

For additional installation instructions, refer to:  
 ANSI NFPA 301

The rate that water is lost by the battery is dependent on several factors: battery condition, ambient temperature, battery use, charge voltage, etc. It is normal for batteries which are not maintenance-free to require topping off about once a month.

A battery's state of charge may be monitored by checking the specific gravity or by open circuit voltage. You may use the following table to evaluate the condition of your batteries:

**Battery Condition Table**

Specific Gravity Measured by Hydrometer @ 80°F	Open Circuit Voltage*			State of Discharge
	12V System	24 V System	32V System	
1.265	12.6 or more	25.2 or more	33.6 or more	Fully Charged
1.225	12.4	24.8	33.1	25% Discharged
1.190	12.2	24.4	32.5	50% Discharged
1.155	12.0	24.0	32	75% Discharged
1.120	11.7 or less	23.4 or less	31.2 or less	100% Discharged

\*Note: Wait at least 5 minutes after charging or discharging before checking specific gravity or open circuit voltage. The battery's voltage needs to stabilize in order to get an accurate reading.

## Troubleshooting Your Battery System

If your battery will not accept or hold a charge, one of the following conditions may exist:

- A BAD BATTERY.** You may have a battery with an open or shorted cell, a battery without any "life" left. Check by charging the battery until all cells have a specific gravity of 1.225 or greater at 80° F. If you are unable to obtain 1.225 in each cell, replace the battery.
  - A BAD BATTERY CHARGER.** If the battery open circuit voltage is low and/or the hydrometer indicates your batteries are low, the battery charger should be providing current to the batteries. If it is not, check the input fuse and check to see that you have charging voltage on the output with no battery attached. Note: You will not get an accurate voltage reading on the output of the charger with no batteries attached. This is checked merely to ensure that you do not have an open circuit on the output.
- The battery charger has a thermal cutout switch to turn the charger off if it is overheating. If you suspect this is the case, refer to the Operating Temperature section on page 13.
- ELECTRICAL LEAKAGE.** You may have a previously unsuspected source of current drain from the battery. To check for a leakage of this sort, disconnect the battery ground cable and connect an ammeter between the negative battery post and ground. If you have a reading over .1 amp, there is a source of current drain from the batteries which must be located and removed.