

Phase Three

Three Stage Smart Charger

Installation/Operation Manual
 Models: PT 80, PT-24-45U, PT-24-95U



Section	Topic	Page
	QUICK REFERENCE DRAWING.....	2
I)	GENERAL INFORMATION.....	3
II)	IMPORTANT SAFETY INFORMATION.....	3
III)	INSTALLATION.....	4
	A) Materials Provided.....	4
	B) Location.....	4
	C) Mounting.....	4
	D) D.C. Output Wiring.....	5
	E) Multiple Unit Parallel Wiring.....	5
	F) A.C. Input Wiring.....	6
IV)	OPERATION.....	7
	A) Three Stage Charge Regimen.....	7
	B) Time-Out Circuit.....	8
	C) Gel-Cell/Lead-Acid Selector Switch.....	8
	D) Remote Monitor Panel Option.....	9
	E) Temperature Compensation Option.....	9
	F) Equalize Timer Option.....	10
	G) Cooling Fan & Filter Maintenance.....	10
	H) Power On Indicator.....	11
	I) Output Ammeter.....	11
V)	APPLICATION NOTES.....	11
	A) Start-Up.....	11
	B) Constant Versus Occasional Use.....	11
	C) Proper Load Sizing.....	11
	D) Operation with Engine.....	11
	E) Operation as a D.C. Power Supply or Radar Rectifier.....	11
VI)	SPECIFICATIONS.....	12
VII)	TROUBLESHOOTING.....	12
VIII)	BATTERY CARE TIPS.....	13
IX)	REFERENCE APPENDIX.....	14
X)	PT 80/PT-24-45U UNIT DIMENSION DRAWING.....	15
XI)	PT-24-95U UNIT DIMENSION DRAWING.....	16

Quick Reference Drawing

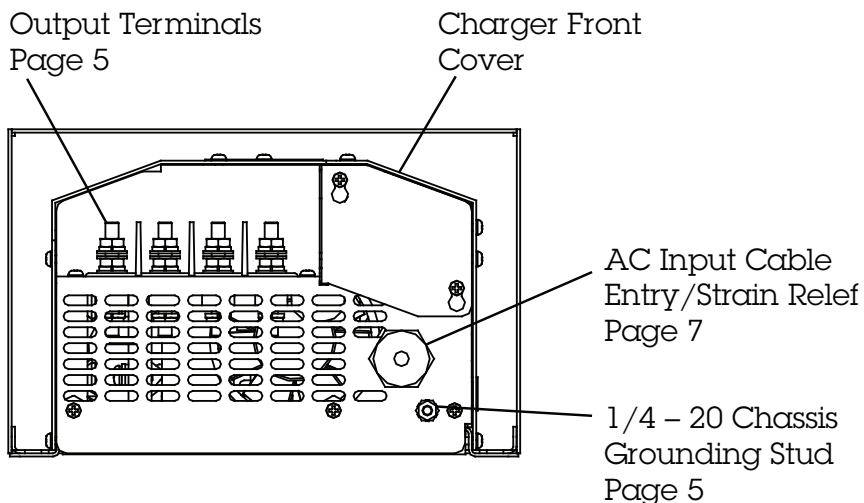
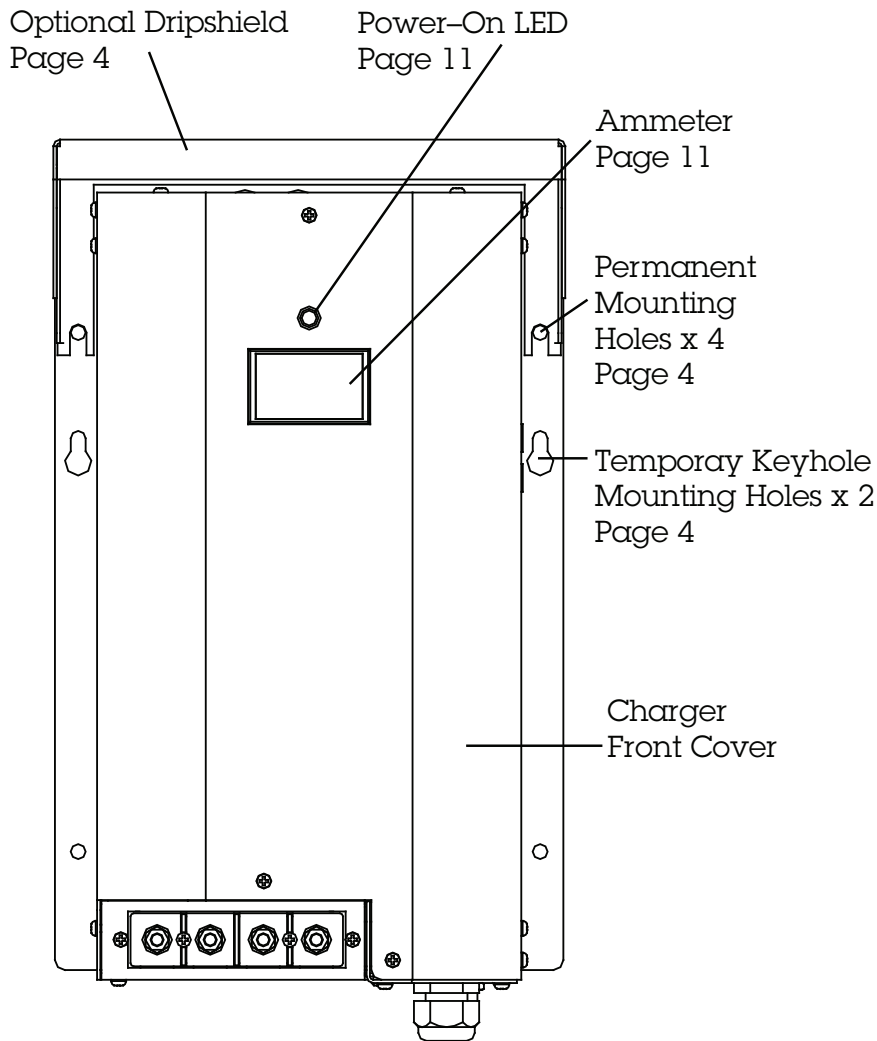

**Note: PT 80/PT-24-45U
illustrated in drawing.**

I) GENERAL INFORMATION

Your Phase Three Series Battery Charger represents a new phase in charger design and performance, employing "smart" switching circuitry which puts batteries through the optimum three-step charge process, adapts for gel-cell or lead-acid batteries, features precise voltage compensation for varying battery temperature, is rated for continuous duty and is housed in a rugged stainless steel and aluminum case.

Following is a brief listing of some of the more important features/options of your Phase Three Charger. Each is fully detailed later in this manual:

- Three step "smart" charging: bulk, absorption, float
- Gel cell/lead-acid switch selects optimum charge/float voltages based on battery type
- Multiple output banks charge independently based on demand
- "Universal" input of 90-264V A.C., 50-60 Hz input with no setting of selector switch required—can be used anywhere in the world
- Current limiting prevents damage from overload
- Cooling fan allows continuous operation at full-rated output
- High charge voltage time-out circuit prevents overcharge during continuous high amperage demand
- Optional temperature compensation sensor (model TCS-12/24) fine tunes output voltage based on battery temperature
- Optional remote panel (model RP) allows remote monitoring of charger phase status and manual re-initialization of three stage charge cycle.
- Optional equalization circuit connection.
- Use as a power supply without in-line battery; allows continued use of D.C. powered electronics (when A.C. is available) in the event that batteries must be taken off-line or removed.
- Built to last – rugged stainless steel and aluminum powder coated case with marinized internal circuitry; drip shield provided.
- Carries CE mark

In addition, your Phase Three Charger carries a full two year warranty against defects in materials or workmanship from the date of purchase. Careful attention to these instructions should help you to enjoy years of trouble-free service.

II) IMPORTANT SAFETY INSTRUCTIONS

1. **SAVE THESE INSTRUCTIONS** — This manual contains important safety and operating instructions for the Phase Three Battery Charger.
2. Before using this battery charger, read all instructions and cautionary markings on (1) the battery charger (2) the battery, and (3) any product powered by the battery.
3. **CAUTION** — To reduce the risk of injury, charge only 6 cell (PT 80) or 12 cell (PT-24-45U & PT-24-95U) lead-acid rechargeable batteries (flooded, AGM, gel or sealed). Other types of batteries may burst, causing personal injury and damage.

3

4. Do not expose charger to rain or spray.
5. Use of an attachment not recommended or sold by NEWMAR may result in a risk of fire, electric shock or injury to persons.
6. To reduce the risk of damage to the electric plug and cord (if plugged into an A.C. outlet), pull by plug rather than cord when disconnecting the charger.
7. Make sure the cord is located so that it will not be stepped on, tripped over, or otherwise subjected to damage or stress.
8. An extension cord should not be used. Use of an improper cord could result in a risk of fire and electric shock.
9. Do not operate the charger with a damaged cord or plug; replace them immediately.
10. Do not operate the charger if it has received a sharp blow, been dropped, or otherwise damaged; take it to a qualified serviceman.
11. Do not disassemble the charger; take it to a qualified serviceman when service or repair is necessary. Incorrect reassembly may result in a risk of electric shock and fire.
12. To reduce the risk of electric shock, disconnect the charger from A.C. source before attempting any maintenance or cleaning.

WARNING—RISK OF EXPLOSIVE GASES

1. WORKING IN THE VICINITY OF A LEAD-ACID BATTERY IS DANGEROUS. BATTERIES GENERATE EXPLOSIVE GASES DURING NORMAL BATTERY OPERATION. FOR THIS REASON, IT IS OF UTMOST IMPORTANCE THAT BEFORE INSTALLING AND USING YOUR CHARGER, YOU READ THIS MANUAL AND FOLLOW THE INSTRUCTIONS EXACTLY.

2. To reduce the risk of battery explosion, follow these instructions and those published by the battery manufacturer and by the manufacturer of any equipment you intend to use in the vicinity of the battery. Review all cautionary markings on these products.

PERSONAL PRECAUTIONS

1. Someone should be within range of your voice or close enough to come to your aid when you work near a lead-acid battery.
2. Have plenty of fresh water and soap nearby in case battery acid contacts skin, clothing or eyes.
3. Wear complete eye protection and clothing protection. Avoid touching your eyes while working near a battery.
4. If battery acid contacts skin or clothing, wash immediately with soap and water. If battery acid enters the eye, immediately flood the eye with running cold water for at least 10 minutes and get medical attention immediately.
5. NEVER smoke or allow a spark or flame in the vicinity of the battery or engine.
6. Be extra cautious to reduce the risk of dropping a metal tool onto the battery. It might spark or short-circuit the battery or other electrical part and cause an explosion.
7. Remove personal metal items such as rings, bracelets, necklaces and watches when working with a lead-acid battery. A lead-acid battery can produce a short-circuit current high enough to weld a ring or the like to metal, causing a severe burn.

8. Use the battery charger for charging gel-cell, AGM or flooded lead-acid batteries only. It is not intended to supply power to a low voltage electrical system other than in a starter-motor application. Do not use the charger for charging dry-cell batteries that are commonly used with home appliances. These batteries may burst and cause injury to persons and damage to property.

9. NEVER charge a frozen battery.

PREPARING TO CHARGE

1. Be sure the area around the battery is well ventilated.
2. Clean battery terminals. Be careful to keep corrosion from coming in contact with eyes.
3. Add distilled water in each cell until battery acid reaches level specified by battery manufacturer. This helps purge excessive gas from cells. Do not overfill. For a battery without cell caps, carefully follow manufacturer's recharging instructions.
4. Study all battery manufacturers' specific precautions such as removing or not removing cell caps while charging and recommended rates of charge.

GROUNDING AND A.C. POWER CORD CONNECTION

1. The charger should be grounded to reduce the risk of electric shock.

(For marine applications only) EXTERNAL CONNECTIONS TO THE CHARGER SHALL COMPLY WITH UL RECOMMENDATIONS AND/OR UNITED STATES COAST GUARD ELECTRICAL REGULATIONS (33CFR183, SUB-PART I)

(For marine applications only) THE INSTALLATION AND PROTECTION OF VESSEL WIRING ASSOCIATED WITH BATTERY CHARGERS SHALL COMPLY WITH ABYC STANDARDS; E-11) AC & DC ELECTRICAL SYSTEMS ON BOATS, AND A-31) BATTERY CHARGERS & INVERTERS.

III) INSTALLATION

A) Materials Provided

- 1) Installation/Operation manual
- 1) Clear plastic output terminal cover

The Phase Three charger is provided completely assembled and ready for installation. The installer must provide four suitable 1/4" mounting screws/washers, as well as D.C. output wiring and connectors. Proper sizes and gauges for the wire and connectors are noted in section III-D following.

B) Location

The charger should be mounted on a wall, bulkhead or other suitable mounting surface as close to the batteries to be charged as possible. Do not mount the charger directly over the batteries as battery fumes may cause excessive corrosion. **WARNING: The charger is not ignition protected so it must not be located in an area where ignition protected equipment is required.** The area should be well ventilated and free from excessive moisture, exhaust manifolds and battery fumes.

Vertical mounting is preferred. However, horizontal mounting is acceptable where absolutely necessary. *Do not mount the charger where water, spray or condensation can occur, as this will shorten*

charger life. It should not be located where there is a possibility of dust or debris being drawn into the unit through the fan. A minimum of 2" clearance around the charger is recommended for proper cooling.

If the charger is located in an extreme heat area, such as an unventilated engine room, and maximum operating temperature is exceeded, an automatic thermal shutdown protection circuit will turn the charger completely off. Thermal cycling will shorten the life of the charger, so if this condition occurs repeatedly, the charger should be relocated. For optimum performance and longer life the charger should not be located in an area of extreme high temperature.

Multiple Charger Installation - Ventilation Mounting Notes

When installing two PT battery chargers near each other it's important to avoid hot air re-circulation, i.e. hot air exhaust from one battery charger being drawn in to the adjacent battery charger's air intake which can cause shut down due to over-temperature which will shorten the life of the battery charger.

Side By Side Mounting

Mounting identical chargers side by side with flanges touching is OK, however if chargers with serial numbers beginning with "14" or higher are mounted adjacent to chargers with serial numbers of "13" or lower, a minimum separation of 8" (200 mm) is recommended. If this is not possible due to space constraints, installing a separator plate between the two chargers is recommended. The separator should extend at least 2" (50 mm) beyond the drip shield front edge and have a height that extends at least 2" more above and below the charger's height, including drip shield if installed.

Vertical Mounting

When mounting one charger directly above another maintain 16" vertical separation between the units if the drip shield is installed on the lower unit. If drip shield is not installed on lower unit, maintain 24" clearance.

C) Mounting

Important Pre-Installation Note: The wiring access port for A.C. input is located on the bottom of the charger. If the factory-installed A.C. cord must be changed for any reason, this should be done before mounting, as access will be difficult afterwards. Also, the drip shield will need to be removed prior to setting the gel/lead acid selector or installing the optional temperature compensation probe. The drip shield is removable with the charger mounted, but if there is limited overhead clearance, the installer may wish to accomplish these tasks also, prior to mounting the charger. For information on these installation procedures, refer to sections III-F and IV-E.

The charger may be mounted on either a metal or non-metal surface*. You will require four screws (wood or machine screws, depending on mounting surface) with washers, sized for 1/4" holes, to mount the charger, plus two temporary holding screws. Note that, in addition to the four permanent mounting holes in the flanges, there is a hole in each mounting flange which is "keyhole" shaped. This is provided to ease vertical installation.

**Per ABYC A-31: A D.C. chassis grounding conductor shall be connected from the case of the battery charger to the engine negative terminal or its bus, and must not be more than one size under that required for the D.C. current-carrying conductors, and not less than 16 AWG.*

Make a mark on the wall or bulkhead where each of the keyhole slots will be located. Then drive a screw about halfway

in at each of these marks. Hang the charger onto the bulkhead using the keyhole slots. Doing this will save you from having to support the charger's weight while you are driving in the four permanent mounting screws. Note: The keyhole slots may be used for additional support screws but they are not to be used as permanent mounting points by themselves.

IMPORTANT: Although the charger is constructed of materials and in a manner which makes it highly resistive to the corrosive effects of moisture in the environment, the charger is not water-resistant. Do not mount the charger where there is a possibility of water entering the unit. Evidence of water entry into the charger will void the warranty.

D) D.C. Output Wiring

Note: Only qualified service personnel should access the output terminals of the charger.

Whether working with existing battery charger output wires or installing new ones, make sure the battery(s) is disconnected from these wires before connecting them to the charger's output terminals.

For secure installation D.C. output wires must be attached with 1/4" crimp ring lug terminals sized appropriately to fit wire gauges as listed below.

The D.C. wire size table below may be used to determine the correct gauge wire based on the model you have and the length of wire run from the charger to the batteries. Once the output wiring has been attached to the charger's output posts, install the clear plastic terminal cover provided with the charger

Model	Length of Wire from Charger to Batteries (in feet)		
	10'	15'	20'
	<u>Minimum Wire Gauge AWG (mm)</u>		
PT 80	#2 (35mm)	#1 (50mm)	#1/0 (70mm)
PT-24-45U	#6 (16mm)	#6 (16mm)	#4 (25mm)
PT-24-95U	#2 (35 mm)	#2 (35 mm)	#2 (35 mm)

*Based on N.E.C. Minimum Wire Size Chart and ABYC 3% Voltage Drop Chart

ENSURE THAT LEADS ARE PROPERLY FUSED AT THE BATTERY. (REFER TO ABYC RECOMMENDATIONS.)

A note about the internal D.C. fuse: The internal wiring of the Phase Three charger is protected against dangerous overheating in the event of an internal short, or reverse polarity hook-up, by an internal d.c. fuse. The fuse is not user replaceable. If this fuse blows the unit must be returned to NEWMAR or a qualified electronic technician for repair.

Typical D.C. wiring configurations are illustrated in FIGURES 1 and 2.

E) Multiple Unit Parallel Wiring

If increased power or system redundancy is required, a second charger may be wired in parallel. The unit is diode protected so it will not be damaged by feedback from the second unit and current limiting will prevent overloading in the case of a failure of one of the units.

FIGURE 1: Simple D.C. Wiring (Preferred Method)

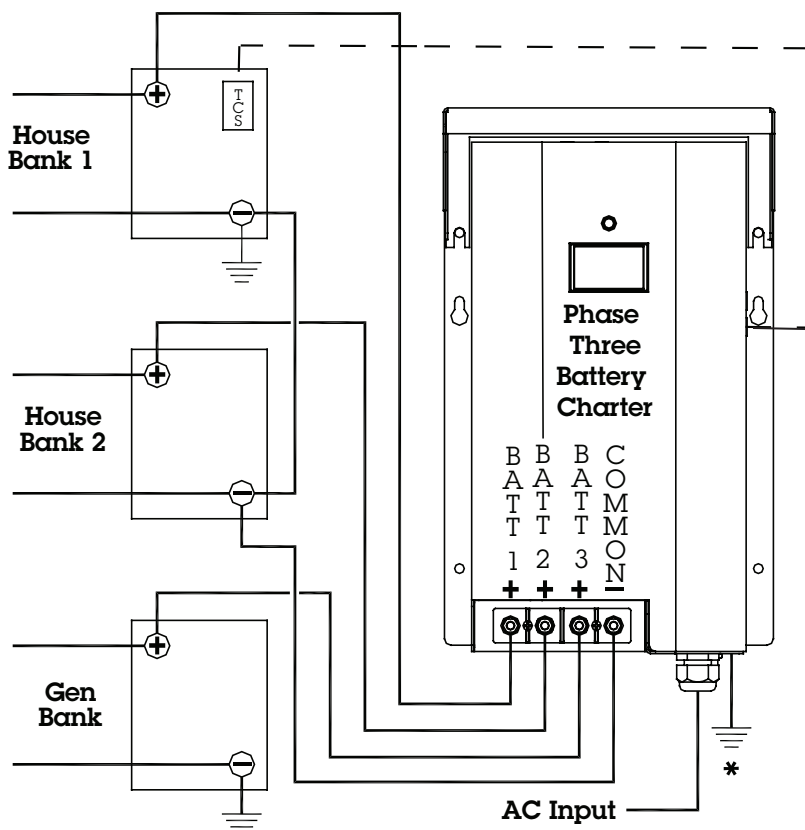

Optional Temperature Compensation Sensor See page 9 for installation information. Use provided cable clamps to secure probe cable

* Per ABYC A-31: A D.C. chassis grounding conductor shall be connected from the case of the battery charger to the engine negative terminal or its bus, and must not be more than one size under that required for the D.C. current carrying conductor and not less than 16 AWG

Note: This diagram does not illustrate a complete system. Refer to ABYC standards E-11 AC & DC electrical system on boats

Important: Install fuses at batteries per ABYC recommendations.

Note: PT 80/PT-24-45U illustrated, same configuration applies to PT-24-95U.

5

FIGURE 2: Wiring With Battery Switch

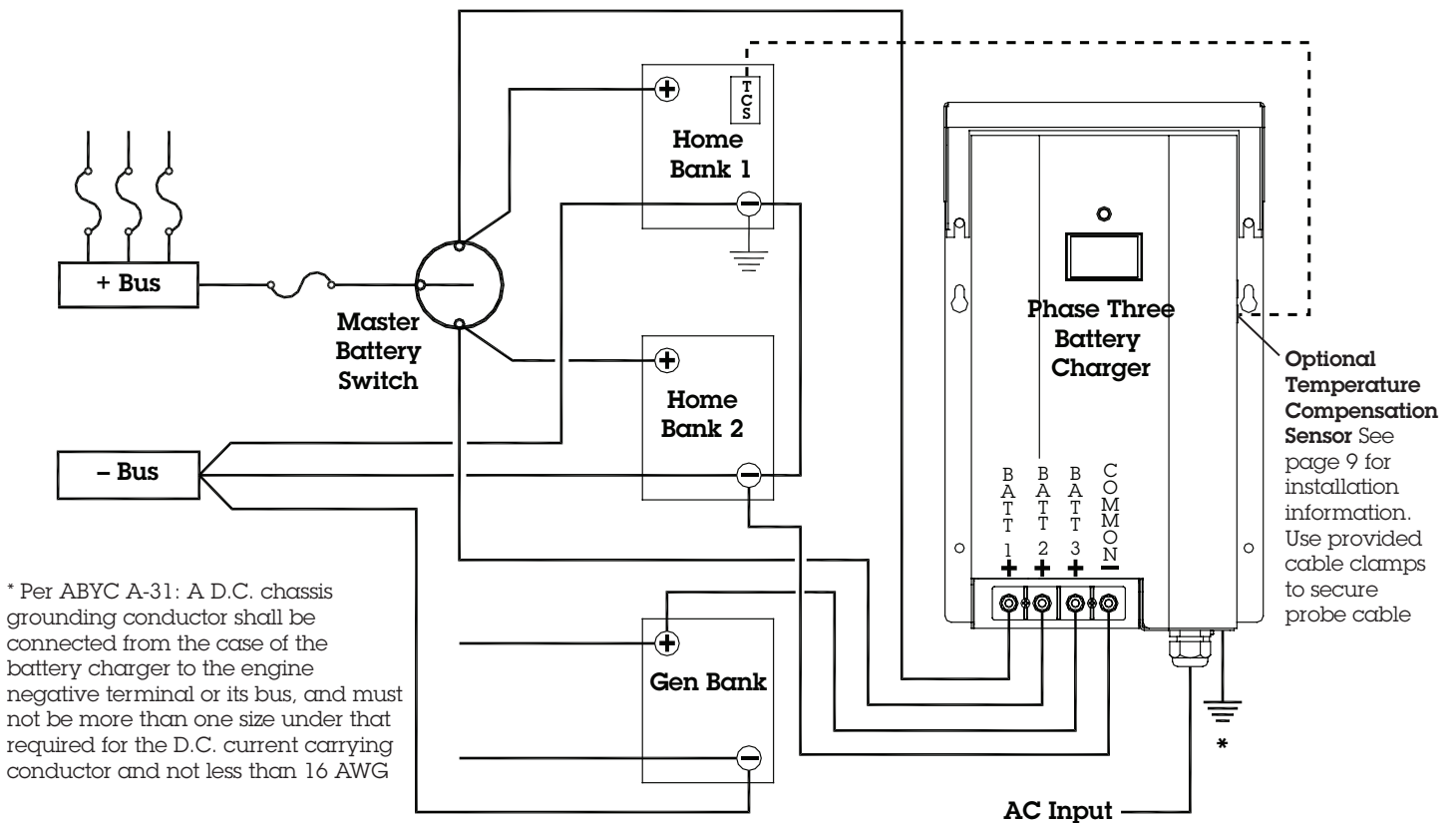

* Per ABYC A-31: A D.C. chassis grounding conductor shall be connected from the case of the battery charger to the engine negative terminal or its bus, and must not be more than one size under that required for the D.C. current carrying conductor and not less than 16 AWG

Optional Temperature Compensation Sensor See page 9 for installation information. Use provided cable clamps to secure probe cable

Note: This diagram does not illustrate a complete system. Refer to ABYC standards E-11 AC & DC electrical system on boats

Note: PT 80/PT-24-45U illustrated, same configuration applies to PT-24-95U

Important: Install fuses at batteries per ABYC recommendations.

Observe the following guidelines when wiring a parallel unit.

- 1) Use only another identical charger model PT 80, PT-24-45U, or PT-24-95U). Do not use a different charger model, either from NEWMAR or from another manufacturer.
- 2) Output wire length and gauge must be identical for each charger to ensure proper load sharing.
- 3) Wire gauge for each charger must be the same used as if a single charger were wired into the system by itself. Wire each battery charger directly to the battery (Figure 1) or battery switch (Figure 2) DO NOT daisy chain charger outputs.

F) A.C. Input Wiring

A.C. input is "universal" and operates in a range of 90-264 VAC, 47-63 Hz. No switch setting is required for either 115V A.C. or 230V A.C. applications. Caution (230V applications only): If A.C. input is derived from a source consisting of two HOT leads (phase-to-phase 230V A.C. input voltage) an external fuse or circuit breaker must be used to protect the unfused (formerly NEUTRAL, now HOT) lead.

A.C. input for the charger must be routed through fuse or circuit breaker on an A.C. distribution panel with proper safety/earth chassis ground in accordance with all applicable local codes and ordinances.

Recommended A.C. Input Wire Size:

115 VAC Input = 14 AWG minimum
230 VAC Input = 16 AWG minimum

Recommended Input Circuit Breaker:

115 VAC Input = 15 Amp
230 VAC Input = 10 Amp

(In marine applications) All charger wiring should be installed in accordance with UL, U.S. Coast Guard and/or A.B.Y.C. regulations and recommendations, as well as all relevant local codes. See REFERENCE APPENDIX at the end of this manual for sources.

A note about the A.C. input fuse: The A.C. input of your charger is protected by an input fuse which is located inside the unit. Due to the current limiting characteristic of the charger, it is highly unlikely that this fuse will blow unless there is some other malfunction within the charger. This fuse is not user-replaceable. Replacement of the input fuse must be performed by a qualified service person.

FIGURE 3: AC Input Wiring

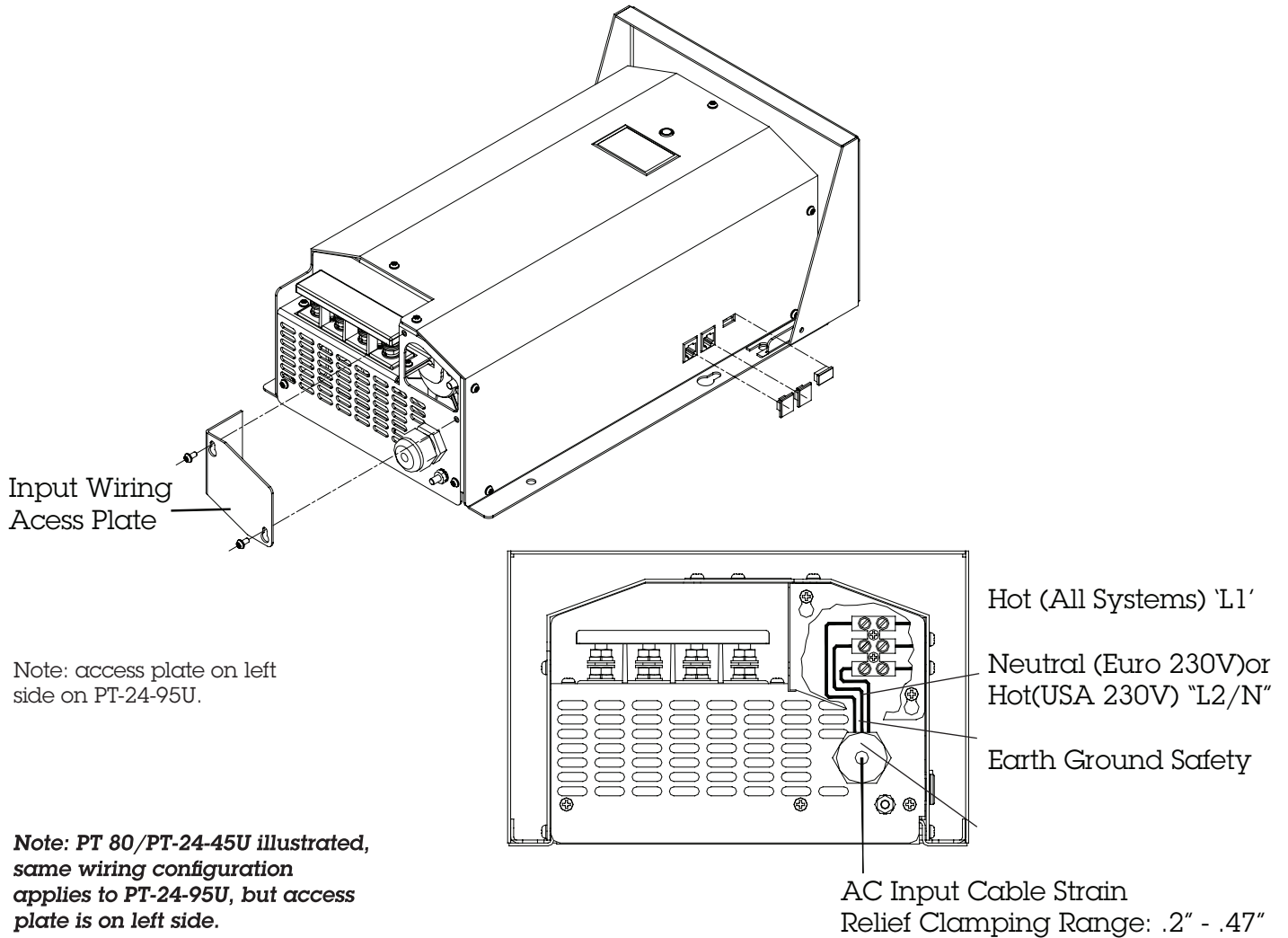

Note: access plate on left side on PT-24-95U.

Note: PT 80/PT-24-45U illustrated, same wiring configuration applies to PT-24-95U, but access plate is on left side.

IV) OPERATION

A) Three Stage Charge Regimen

The Phase Three Battery Charger utilizes the three stage charge regimen which is widely recommended by battery manufacturers for allowing the fastest possible recharge time without loss of batteries' electrolyte (gel or liquid) which may be caused by sustained charging at higher voltages.

This three stage regimen is initiated each time A.C. is first applied, when drained batteries are most likely to be encountered, and proceeds slowly or quickly through each stage depending on the battery's relative state of charge. (This also occurs when the reinitialize button on the optional remote panel is activated; see Remote Panel Option section for more information). **Note:** An audible "clicking" noise from an internal relay may be heard when the charger switches from one phase to another. This is normal operation. The charge regimen proceeds as follows:

1) Bulk Phase: When batteries are significantly discharged the charger responds initially by delivering a high amount of D.C. current, at or near the charger's maximum rated output, in order to rapidly replenish them. It is during this stage that charging current is maintained at a high level as battery voltage increases. Bulk charging continues until battery voltage reaches the "charge" voltage level (where batteries are at about 75-80% of capacity). A current limit circuit prevents charger overload during this maximum output stage.

Note: During this bulk phase the charger is in a "constant current" mode; therefore, output current will stay constant while output voltage decreases. Full output voltage is achieved and maintained only when the charger switches to the absorption stage.

2) Absorption Phase: During this second stage of the charge cycle, battery voltage is maintained at the "charge" voltage level. Output current begins to taper off as the battery plates become saturated. Charge voltage is maintained until the current sensing circuit detects that output current has tapered to about 5-15 % of charger

rating*. At this point the batteries are at about 95 % of full charge and the Phase Three charger switches to the third and final stage of the charge cycle.

* **Note:** The absorption phase may also be ended by the time-out circuit. See section IV-B, for a complete explanation of the purpose and functioning of the time-out circuit.

3) **Float Phase:** For extended battery life the Phase Three then automatically switches to a lower float voltage level. This float charge keeps batteries at peak condition without overcharging. The charger may be left in this stage for lengthy periods of time without attention (though periodic checks of electrolyte level in flooded batteries is recommended). It is not necessary or recommended to shut the charger off when this stage is reached.

A typical three stage charging cycle is illustrated in FIGURE 4.

FIGURE 4: Typical Charger Output Graph (into battery without load)

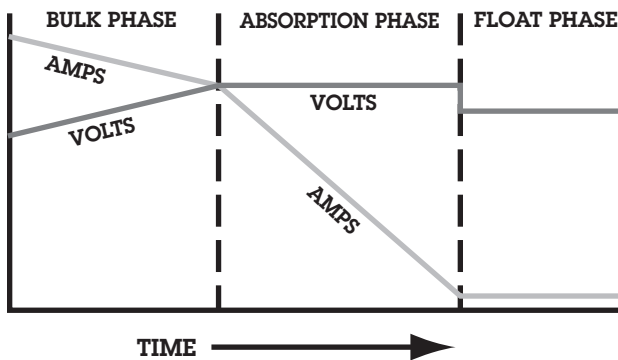

* Approximately 10 hours maximum at factory setting.

Note: If a load is applied during the absorption phase, the charger may revert to the bulk phase depending on the total current draw. When the charger times-out into the float phase, it will remain in that phase regardless of current draw. The charger is still able to deliver full output current when in the float phase. To re-initialize the three stage process shut the charger off momentarily, then back on again (or press the reinitialize button on the optional remote panel)

B) Time-Out Circuit

Batteries have a tendency to lose their electrolyte and may be damaged if they are maintained for long periods of time in the elevated voltage of the absorption phase. Therefore, the Phase Three Charger employs a special time-out circuit. This circuit is initialized each time A.C. is first applied to the charger (or when the reinitialize button on the optional remote panel is activated) and runs for a pre-set interval before forcing the charger to go into the float (lower voltage) mode. The functioning of the charger during this interval is as follows:

If the current demand of the batteries/load falls below 5-15 % of the charger's output capacity prior to the circuit timing-out, the charger will automatically switch to the float mode. If demand rises to about 10-20 % of charger output capacity, it will return to the elevated output voltage of the absorption phase. This switching back and forth between modes may occur until the circuit times-out (8-10 hours after A.C. is first applied), after which the charger will remain at float voltage, until the circuit is re-initialized, either by turning the charger off and then on again or by pressing the re-initialize button on the optional remote panel.

Installation Note: The time-out circuit of the PT charger has been set at about 8-10 hours, which is appropriate for battery systems within the capacity range specified on the front panel of the charger. If the charger is used with a battery system with a capacity near (or outside) the upper or lower ranges of the specified range of the charger, adjustment of the internally located time-out circuit adjustment pot may be recommended. The procedure is as follows:

(Caution: Ensure A.C. input has been disconnected before proceeding)

1) Remove the three screws on the front panel and seven screws on the sides of the unit.

2) Remove the main cover from the charger base, taking care not to bend the two jacks on the right side of the charger out of position. Locate the potentiometer labeled "TIMER ADJ" on the small charger function circuit board on the right side of the charger.

3) Using a small flat tip screwdriver, turn the potentiometer clockwise to increase the amount of time the charger remains in the absorption mode before timing out, or counterclockwise to decrease the amount of time. The approximate ranges are illustrated below.

FIGURE 5: Adjusting the Time-out Circuit

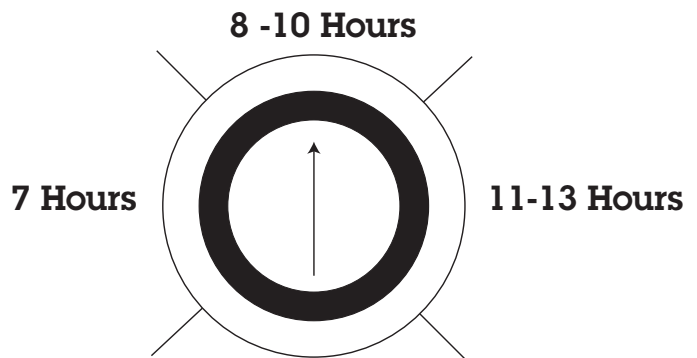

Note: Once the time-out circuit has put the charger into float mode, the charger will remain in this mode. Since the Phase Three Charger is well regulated, it is able to deliver its full rated output current in this mode and battery discharge will not occur (provided load current does not exceed charger rating and output wiring is properly sized).

4) Reinstall the charger cover

C) Gel-Cell — Flooded/AGM Switch

According to most battery manufacturers, the ideal charge regimen for gel-cell and flooded (wet) lead-acid or AGM (Absorbed Glass Mat) batteries differs somewhat.

The gelled electrolyte in a sealed battery may be lost or damaged by high voltage and, once lost, cannot be replaced as it can with a wet lead acid battery. Manufacturers of gel-cells usually recommend an ideal charge voltage which is slightly lower for a gel-cell than a lead-acid battery. (The charge regimen recommended for AGM batteries is typically similar to that of flooded lead-acid batteries.)

However, when the charger is in the float voltage mode over lengthier periods of time, gelled electrolyte in a sealed battery is not susceptible to evaporation, as is the non-immobilized electrolyte

of a wet lead acid battery. This evaporation can be accelerated by the applied voltage. Consequently, the ideal float voltage is slightly higher for a gel-cell than a lead-acid or AGM battery.

The ideal charge/float regimen has been programmed into the Phase Three Charger for either sealed gel-cell or flooded lead-acid/AGM batteries. Simply make the proper selection for your battery type via the slide switch on the right side of the charger. The switch positions are indicated on the Charger's left side panel (see Figure 6). Use a ball point pen or similar object to slide it into the correct position.

Note: A wide variety of batteries are now available which do not conform to conventional descriptions as "gel-cell" or "lead-acid". You are advised to consult the manufacturer of your particular battery as to proper charging regimen, and use the battery type selection switch setting which most closely conforms to the recommended voltages.

See the **SPECIFICATIONS** section for the actual preset charge and float voltages for the PT-80 and PT 80, PT-24-45U, and PT-24-95U.

D) Remote Monitor Panel Option

A Remote Monitor Panel is available from NEWMAR (model RP) which will enable you to monitor the charger's status at-a-glance from a remote location. Red and green L.E.D.'s indicate whether the charger is in the bulk, absorption or float phase of the charge cycle. In addition, the panel features a re-initialize button, which, when pressed, will cause the charger to restart the three phase cycle. This resets the time-out circuit (see section B, above) Time-out Circuit, above). Note: The charger may not stay in the bulk or absorption mode after pressing the re-initialize button. If batteries are at or near full charge, the charger will quickly revert to the float mode.

The panel comes pre-wired with 30' of cable and 4 mounting screws. Simply install the panel at the desired location and insert the plug on the end of the cable into the remote panel jack which is located on the right side of the charger. (See Figure 10.) The remote panel jack is identified on the front panel.

Note: Inadvertently putting the remote panel plug into the temp compensation jack (or vice versa) will not harm the charger. If the panel does not appear to function correctly, check to see that it is plugged into the correct jack.

If additional cable length is required, additional cable is commonly available from most electronics supply retailers such as Radio Shack/Tandy. Request a 6 conductor modular-to-modular line cord (part number 279-422, 25 feet long) and 6 pin modular in-line non-reversing coupler (279-423).

E) Temperature Compensation Option

Because low battery temperature increases resistance to charging and high battery temperature reduces impedance, requiring a lower charge voltage, the ideal charging voltage will vary depending on the temperature of the battery's environment when it is being charged.

If a charger has a fixed output voltage which is ideal at, say 72° F, that same output may cause a battery charged in a consistently high temperature environment to be overcharged, resulting in excessive loss of electrolyte. Conversely, if the batteries are in a consistently cool environment, they may be chronically undercharged, resulting in sulfation of the battery plates. Either of these two conditions will shorten battery life.

FIGURE 6: Temperature Compensation Sensor and Remote Panel Installation

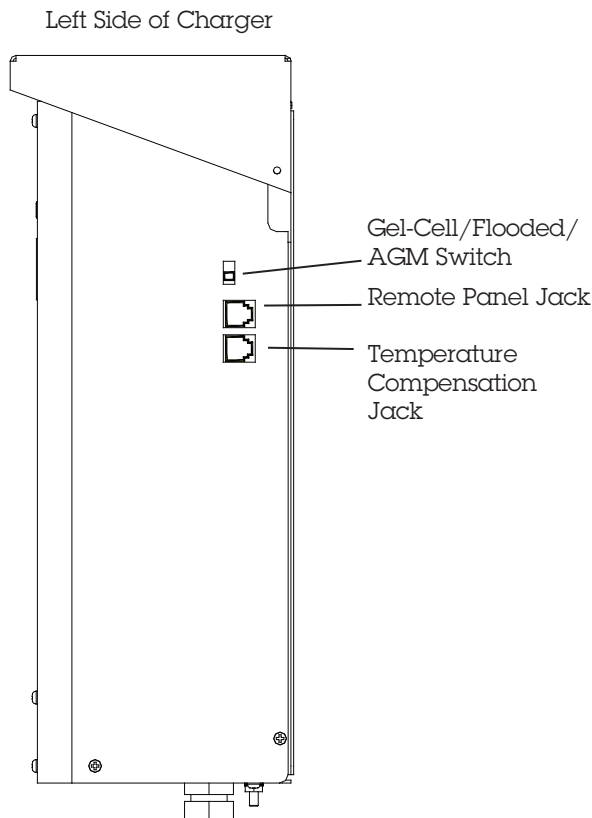

Therefore, the Phase Three charger is designed to utilize an optional remote sensor (available from NEWMAR; model TCS-12/24) which provides automatic temperature compensation. The remote sensor will signal the charger to fine tune its output voltage so that it is properly matched to the temperature of the battery/battery environment. The adjustment rate is approximately -5 mV per cell per °C. (Note: The temperature compensation option is strongly recommended for sealed, valve-regulated, AGM or gel-cell batteries.)

The remote sensor is provided with 30' of cable. One end of the cable is plugged into the temperature compensation jack which is located on the right side of the charger (see FIGURE 6). The location of temp sensor jack is identified on the front panel.

If additional cable length is required, additional cable is commonly available from most electronics supply retailers such as Radio Shack/Tandy. Request a 6 conductor modular-to-modular line cord (part number 279-422, 25 feet long) and 6 pin modular in-line non-reversing coupler (279-423).

The sensor itself should be mounted on the inside of the battery box, or more ideally, mounted onto one of the batteries using a clamp or a small amount of silicon-type adhesive. The sensor has a hole in the center which will accommodate a # 6 screw. If you have access to the exterior of a wall of the battery box, you may drill a hole in the wall of the box and run the screw through to mount the sensor onto the interior wall. Use caution when drilling so that you do not accidentally puncture the case of any battery inside the box.

Important note: When wiring multiple chargers in parallel (see section III-E) and using the temperature compensation option, you must use a separate sensor for each charger, and the sensors must be mounted close together in the same battery box or on the same battery for proper operation.

Without the temperature sensor installed the output of the charger will be at the nominal voltages specified in the chart below at 72° F (22.2° C). The absorption/float output voltage settings at that temperature are listed in the chart.

To provide some examples which clarify the effect of the temperature compensation sensor, the chart lists the absorption/float output voltages of the charger when batteries are at 72° F (or when the sensor is not installed), and at cold (50° F) or hot (90° F) battery temperatures with the sensor installed:

Temperature Compensation Chart

Battery Temp.		Output V D.C: 12 Volt Models				Output V D.C: 24 Volt Models			
		Charge		Float		Charge		Float	
° F	° C	Gel-Cell	Lead Acid	Gel-Cell	Lead Acid	Gel-Cell	Lead Acid	Gel-Cell	Lead-Acid
50	10	14.4	14.6	14.0	13.8	28.8	29.2	28.0	27.6
72	22.2	14.0*	14.2*	13.6*	13.4*	28.0*	28.4*	27.2*	26.8*
90	32.2	13.7	13.9	13.3	13.1	27.4	27.8	26.6	26.2

* Factory pre-set voltages without temperature compensation option installed

F) Equalize Timer Option

Some manufacturers of flooded lead-acid batteries recommend a charging process known as equalization for extended battery life. This process involves occasionally charging a wet lead-acid battery at a very high voltage for a short period of time in order to completely de-sulphate each of the battery plates, essentially equalizing their voltage. The installer of the Phase Three charger may choose to wire in this option at the time of installation.

Note: The equalization process is not recommended for sealed valve regulated or gel-cell batteries.

The equalize circuit (connector located inside the PT charger) should be wired through a manual or electric timer which provides a closed contact when engaged and an open circuit when timed out (SPST — Single Pole Single Throw). Do not use a manually operated switch for activating the equalize circuit. This is because unless the charger is reverted to a safe float voltage in a timely manner, the batteries will almost certainly be damaged or destroyed. The timer should be a 0-12 hour type, capable of carrying a minimum of 100 mA at 5V D.C.

CAUTION: Do not install the timer in an area requiring ignition protected equipment unless it has been certified to meet ignition protection requirements.

The equalization circuit of the Phase Three charger boosts output voltage to approximately 8 % above float voltage. Refer to the battery manufacturer's instructions when deciding the appropriate time period setting for this voltage to achieve proper equalization, while ensuring batteries are not damaged by increased battery temperature. **This installation should only be performed by a qualified technician.**

Installing the timer requires a mating connector with dual wires which are plugged into a jack on the internal charger function circuit board. The connector/wire assembly is available from NEWMAR. Request part number 873-3716-0, CFB Equalize 2 pin assembly. Proceed with the installation as follows:

(Caution: Ensure A.C. input has been disconnected before proceeding)

- 1) Remove the three screws on the front panel and seven screws on the sides of the unit.
- 2) Remove the main cover from the charger base, taking care not to bend the two jacks on the right side of the charger out of position.
- 3) Locate the two-pin header labeled "J2" on the top of small charger function circuit board which is located on the right side of the charger. Insert the mating connector and route the two control wires through one of the charger's vent holes. Secure the wire as it exits the charger using a cable clamp or wire ties.

- 4) Replace the charger cover.

G) Cooling Fan & Filter Maintenance

To maximize the life of the internal components and to allow continuous operation at full rating, the Phase Three employs two integral cooling fans. The fans operate independently of each other and will vary speed and turn on/off depending upon load conditions and ambient temperature.

The charger is equipped with an air filter located on the top panel of the case, designed to reduce particulate matter from entering the charger by the intake of the cooling fans.

This filter should be removed periodically and rinsed with clean water to ensure adequate air flow, otherwise if the filter becomes clogged the charger will overheat and produce less power or shut down altogether and enter a thermal cycling mode.

The maintenance frequency will depend on the environment of the application, at minimum the filter should be inspected/serviced every 3 months. If the charger is mounted in a dusty, particle-filled, or oily atmosphere inspection and cleaning will need to be more frequent and you will need to set your maintenance schedule accordingly.

Filter cleaning/replacement procedure (see illustration next page)

- 1) Disconnect ac power from the charger
- 2) If the provided drip shield has been installed above the charger it will need to be removed to access the filter: Remove the drip shield by loosening the upper mounting bolts and then slide the drip shield up and off of the battery charger.
- 3) Remove the filter retainer cap by pushing up on the rim of the cap and remove the filter.
- 4) Rinse/wash the filter and allow it to dry before replacing and securing the retainer cap.

Replacement Filters

If the filter is ever damaged a replacement kit is available from Newmar. Specify part number 999-9450-0. If obtaining filter from another source specify a ¼" thick filter medium of 30 PPI density which you can cut to size.

FIGURE 7: Cooling Fan and Filter Maintenance

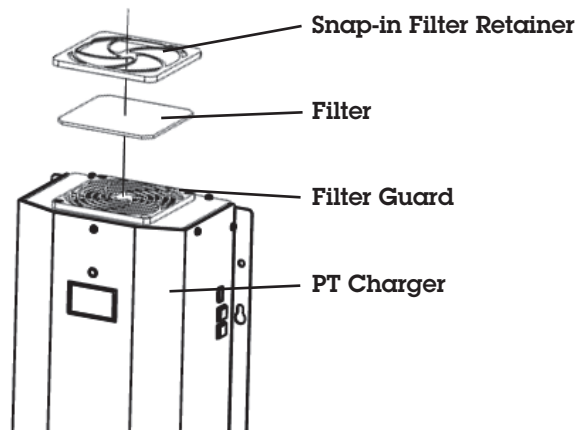

D) Output Ammeter

This meter will indicate total charging output current for all battery banks connected.

H) Power On Indicator

This green LED will glow whenever the charger is receiving A.C. power.

V) APPLICATION NOTES

A) Start Up

1) Before powering up your charger, check for tight electrical connections to each battery in your system. Switch off any D.C. loads on the batteries. Apply A.C. power. Observe the D.C. ammeter on the front panel. This meter displays the total D.C. output of the charger, through all banks. It will give some indication of the overall state of charge of your batteries. If the meter is reading mid-scale or higher, it is an indication that the batteries are in a relatively low state of charge. The charger, sensing this, is supplying high current to the batteries. If the meter needle is at or near the bottom of the scale the batteries are at or nearing full charge.

2) Apply a load to the charger by switching on some lights, a pump or some other D.C. appliance. Observe the charger meter. It should read approximately the same as the expected current draw of the appliance. As current is demanded from the battery system, the charger will automatically increase its output in response to the increased load demand. When load current exceeds 10-20 % of the charger's rated capacity, the charger will go into the absorption mode and remain there until current drops below 5-15 % of capacity or until the time-out circuit cycle is complete.

B) Constant Versus Occasional Use

In general, it is recommended that the charger be left connected continuously to the A.C. distribution system so that it will be in operation whenever A.C. is available. This will maintain batteries at peak voltage and will automatically compensate for the natural self-discharge of the battery system. When a load is applied to the battery system the charger's output will automatically increase to supply the current which would otherwise draw battery voltage down. Repeatedly allowing batteries to become completely

discharged before recharging will greatly shorten their life. Leaving the charger on continuously will prevent this.

While the output regulation of the charger will minimize battery gassing and water loss, monthly checks of the electrolyte level (for wet lead acid batteries) are still strongly recommended. Some water loss is an inevitable aspect of the charging process, and maintaining the correct electrolyte level in your batteries is the most important thing you can do to assure their maximum performance and long life.

C) Proper Load Sizing

The Phase Three Charger is rated for continuous duty. While the charger cannot be damaged by overloads that exceed this continuous rating, excessive load demands may draw battery voltage down faster than the charger can re-supply it. If battery voltage continues to drop and the output current is at maximum while the charger is in service, check to see that your average D.C. loads are not exceeding the charger's rated output. If they are, you may wish to consider adding another charger in parallel to provide sufficient power for your requirements (see section III-E, Multiple Unit Parallel Wiring.)

D) Operation With Engine

It is perfectly acceptable to allow the charger to remain on when the engine is started and while it is running. The current limit feature of the Phase Three Charger will protect against any damage due to the high current demands of engine cranking. Output diodes will prevent any back-feed of current into the charger from the alternator while the engine runs.

As the alternator starts to charge the battery, the charger output will decrease. When the battery voltage exceeds the rated output voltage of the charger it will shut off and stay off as long as the batteries are in this high state of charge. If the battery voltage should drop below the charger's rated output voltage it will automatically return to service.

E) Operation as a D.C. Power Supply (stand-alone D.C. power source) or Radar Rectifier

Most battery chargers are not suitable for powering electronic devices directly, without a battery attached to the output, as the high ripple and pulsing D.C. output (i.e., rectified A.C. output) can interfere with the operation of the device. However, this charger employs a circuit that produces an extremely well-filtered D.C. output. Therefore it is able to power virtually any D.C. powered device (within the unit's rating) without the battery attached in-line (if, for instance, the battery must be removed for any purpose and A.C. is still available). All but the most sensitive D.C. powered electronic devices will function as normally as if powered by a battery. In addition, the current limiting circuitry enables the charger to handle the high start-up surges associated with inductive loads, such as D.C. motors in radar sets.

VI) SPECIFICATIONS

Input Voltage/Frequency: 90-264V A.C.; 47-63 Hz

Power Factor: .95 @ 230V A.C., .98 @ 115V A.C.

Input Current @ Full Load:

PT 80 & PT-24-45U: 7 amps @ 230V A.C.; 12 amps @ 115V A.C.

PT-24-95U: 14 amps @ 230V A.C.; 26 amps @ 115V A.C.

Output Current @ 115/230V A.C. Input:

PT 80: 80 amps maximum in Bulk / Absorption / Float Phases

PT-24-45U: 45 amps maximum in Bulk / Absorption / Float Phases

PT-24-95U: 95 amps maximum in Bulk / Absorption / Float Phases

Nominal Output Voltages (without Temperature Compensation option installed or at 22.2 °C with Temperature Compensation option installed):

Temperature Compensation (with Sensor Installed):

- 5 mV per cell per ° C

Temperature Rating: -10° C to +60° C; Derate linearly from 100 % @ 50° C to 80 % @ 60° C

Recommended Battery Type/Capacity: Gell-Cell, Flooded or Sealed Lead-Acid;

PT 80 : 6 cell, 140-700 Amp-Hour

PT-24-45U: 12 Cell, 80-400 Amp-Hour

PT-24-95U: 12 Cell, 180-950 Amp-Hour

Protection Features: Input Fuse, Output Fuse, Current Limiting, Over Voltage Protection, Cooling Fans, Automatic Thermal Shutdown/Recovery

Case Size: PT 80 & PT-24-45U

14.8" H* x 9.6" W x 5.6" D*

37.6 cm* x 24.4 cm x 14.2 cm*

*Add 1" (2.54 cm) to height and .5" (1.27 cm) to depth when installing optional drip shield.

Weight: 15.2 lbs. (6.9 kg.)

Case Size: PT-24-95U

17.5" H* x 12.0" W x 7.2" D*

44.5 cm* x 30.5 cm x 18.3 cm*

*Add 2" (5.08 cm) to height and 1" (2.54 cm) to depth with drip shield installed.

Weight: 24.5 lbs. (11.1 Kg.)

Compliance: Carries the CE Mark

Setting	PT 80		PT-24-45U & PT-24-95U	
	Charge @ 50% load	Float @ .5 amp load	Charge @ 50% load	Float @ .5 amp load
Gel-Cell	14.0V D.C.	13.6V D.C.	28.0V D.C.	27.2V D.C.
Flooded/AGM	14.2V D.C.	13.4V D.C.	28.4V D.C.	26.8V D.C.

VII TROUBLESHOOTING

Note: The PT 80, PT-24-45U, and PT-24-95U chargers incorporate a self-contained A.C. to D.C. conversion module which utilizes numerous automatic protection circuits. The A.C. input and D.C. output fuses which protect internal wiring are housed inside the charger module. Under most circumstances these fuses will fail only if the charger has an internal fault. Hence, they are not intended to be user-replaceable and any condition which has caused a blown fuse will likely require repair of other internal circuitry by a qualified technician. If an apparent charger fault cannot be corrected using any of the recommendations in this section, the charger should be returned to the factory or place of purchase for inspection and repair or replacement.

Problem	Possible Cause	Solution
A. Batteries not coming up to full charge	<ol style="list-style-type: none"> 1. Extremely discharged batteries requiring long recharge time 2. Charger limiting its output due to overload or over-temperature conditions 3. Fan not operating properly, causing charger to over-heat, reducing or ceasing power output 	<ol style="list-style-type: none"> 1. Turn off all D.C. loads and allow charger 24-48 hours to recharge batteries 2. Reduce D.C. load and/or determine cause of over-temperature condition (see section III-B, Location) 3. Check to ensure there is no blockage at fan intake on bottom of charger. Replace fan if necessary (see section IV-G, Cooling Fan)
B. Charger continues to charge at 3 amps or more—does not taper back	<ol style="list-style-type: none"> 1. D.C. load connected to batteries drawing current (not a problem condition) 2. Bad cell in one of the batteries to which the charger is connected 	<ol style="list-style-type: none"> 1. Turn off main battery switch to D.C. electrical panel or turn off all D.C. loads if you wish to confirm charger will output minimal amperage to fully charged batteries 2. Check for shorted cell in wet lead-acid batteries using a hydrometer. Refer to manufacturer for testing maintenance-free batteries

Problem	Possible Cause	Solution
C. No charger output, even when all connections have been checked, A.C. is applied to the charger, and a D.C. load is applied to the batteries	Blown input or output fuse or other internal defect	Return to servicing dealer for failure analysis or contact NEWMAR for Return Authorization Number
D. Reverse polarity connection has caused charger to have no output	D.C. output fuse and other internal components likely blown	Return to servicing dealer for failure analysis or contact NEWMAR for Return Authorization Number
E. High voltage measured across charger output terminals	1. Batteries not connected to charger. It is normal to read 1/2 volt higher across any output bank when no batteries are connected. 2. Equalize function is activated	1. Check for tight connection of charging leads to batteries 2. Check to verify proper installation and operation of equalize timer
F. Charger will not stay in bulk/absorption phase when re-initialize button on remote panel is pressed.	Batteries at or nearing full charge (not a problem condition)	Verify proper operation by cycling A.C. off and on (or press reinitialize button on optional remote panel) then applying a large D.C. load
G. Charger outputs high current for short period, shuts off. After cooling, the cycle repeats itself.	Fan Failure	Return to servicing dealer for failure analysis or contact Newmar for RMA

Factory Contact Information

If a problem with your charger persists after you have applied the above-outlined solutions, or if you have any questions about the installation and proper operation of your charger, please contact NEWMAR's Technical Services Manager:
 Phone: 714-751-0488 — From the hours of 7:00 A.M. to 4:30 P.M. weekdays, P.S.T.
 Fax: 714-957-1621 — Anytime
 E-Mail: techservice@newmarpower.com — Anytime

We will be happy to consult with you to resolve any problem you may have. If it appears the charger must be returned to the factory for repair we will issue a Return Materials Authorization at that time.

VIII) BATTERY CARE TIPS

Regular maintenance and proper care will assure you reliable service from the most depended upon and sometimes most neglected items, your batteries and battery charger. NEWMAR battery chargers are designed to keep your batteries fully charged but your batteries also need proper regular maintenance to provide a maximum life of service.

ALWAYS READ AND FOLLOW THE BATTERY MANUFACTURER'S INSTRUCTIONS

Battery Installation

Batteries must be securely mounted to prevent them from falling over when the vehicle or boat is in motion. A loose battery can do serious damage. Batteries should be mounted in a battery box to contain any acid spill. Batteries give off a certain amount of hydrogen gas when they are charging. When concentrated, this gas is highly explosive. Therefore make sure they are in an accessible place with adequate ventilation for any hydrogen gas discharge.

Cleaning Batteries

Dirt and electrolyte salts can build up on the top of your batteries. This accumulation conducts electricity stored in the battery and can cause the battery to discharge by itself. Therefore, at least twice a year, it is a good idea to disconnect the battery cables and scrub the battery with a baking soda solution. Rinse with fresh water and dry with a clean cloth.

You may wish to purchase a set of terminal post corrosion prevention rings. These are alkali-saturated felt rings that slip over the battery post to reduce corrosion. Do not apply grease to any part of the battery terminals, but you may use an occasional light spray of silicone lubricant.

Routine Checks and Maintenance

Batteries should periodically be "exercised" (slowly discharged and then recharged) to keep them in top condition. New batteries may need to be exercised before they will be capable of their full rating.

If your batteries are not the sealed type, distilled water should be added to them whenever needed. The electrolyte should cover the plates by about 1/2", allowing a small air space at the top. Do not fill the cells up to the filler cap as this could cause the battery to sputter out electrolyte when it is being charged. Only distilled water should be used never plain tap water. Tap water contains chemicals and elements that can alter the properties of the electrolyte, including specific gravity. Some chemicals may also create an insulating coating on the battery plates which will retard current flow.

The rate that water is lost by the battery is dependent on several factors; battery condition, ambient temperature, battery use, charge voltage, etc. It is normal for batteries which are not maintenance-free to require topping off about once a month.

A battery's state of charge may be monitored by checking the specific gravity or by open circuit voltage. You may use the following table to evaluate the condition of your batteries:

Battery Condition Table

Specific Gravity Measured by Hydrometer	State of		
	Open Circuit Voltage		Discharge @ 80° F
	12 Volt System	24 Volt System	
1.265	12.6 or more	25.2 or more	Fully Charged
1.225	12.4	24.8	25 % Discharged
1.190	12.2	24.4	50 % Discharged
1.155	12.0	24.0	75 % Discharged
1.120	11.7 or less	23.4 or less	100 % Discharged

* Note: Wait at least 5 minutes after charging or discharging before checking specific gravity or open circuit voltage. The battery's voltage needs to stabilize in order to get an accurate reading.

Troubleshooting Your Battery System

If your battery will not accept or hold a charge, one of the following conditions may exist:

- A BAD BATTERY.** You may have a battery with an open or shorted cell, a battery without any "life" left. Check by charging the battery until all cells have a specific gravity of 1.225 or greater at 80° F. If you are unable to obtain 1.225 in each cell, replace the battery.
- A BAD BATTERY CHARGER.** If the battery open circuit voltage is low and/or the hydrometer indicates your batteries are low, the battery charger should be providing current to the batteries. If it is not, check the input fuse and check to see that you have charging voltage on the output with no battery attached. Note: You will not get an accurate voltage reading on the output of the charger with no batteries attached. This is checked merely to ensure that you do not have an open circuit on the output.

The battery charger has a thermal power reduction circuit to protect the charger from overheating. If you suspect this is the case, refer to the INSTALLATION section for information about proper charger location.

3. **ELECTRICAL LEAKAGE.** You may have a previously unsuspected source of current drain from the battery. To check for a leakage of this sort, disconnect the battery ground cable and connect an ammeter between the negative battery post and ground. If you have a reading over .1 amp, there is a source of current drain from the batteries which must be located and removed.

IX) REFERENCE APPENDIX

- For more information about boat wiring to conform to U.S. Coast Guard regulations, write:

Superintendent of Documents
Government Printing Office
Washington, DC 20402

Request: 33 CFR 183 Subpart I

- For information about American Boat and Yacht Council recommendations for boat wiring, write to:

American Boat and Yacht Council
3069 Soloman's Island Road
Edgewater, MD 21037

Request: Standards and Recommended Practices for Small Craft.
AC & DC systems: Section E11
Battery Chargers and Inverters: Section A-31

- For additional installation instructions, refer to:
ANSI NFPA 302

X) UNIT DIMENSION DRAWING

Models: PT 80 & PT-24-45U

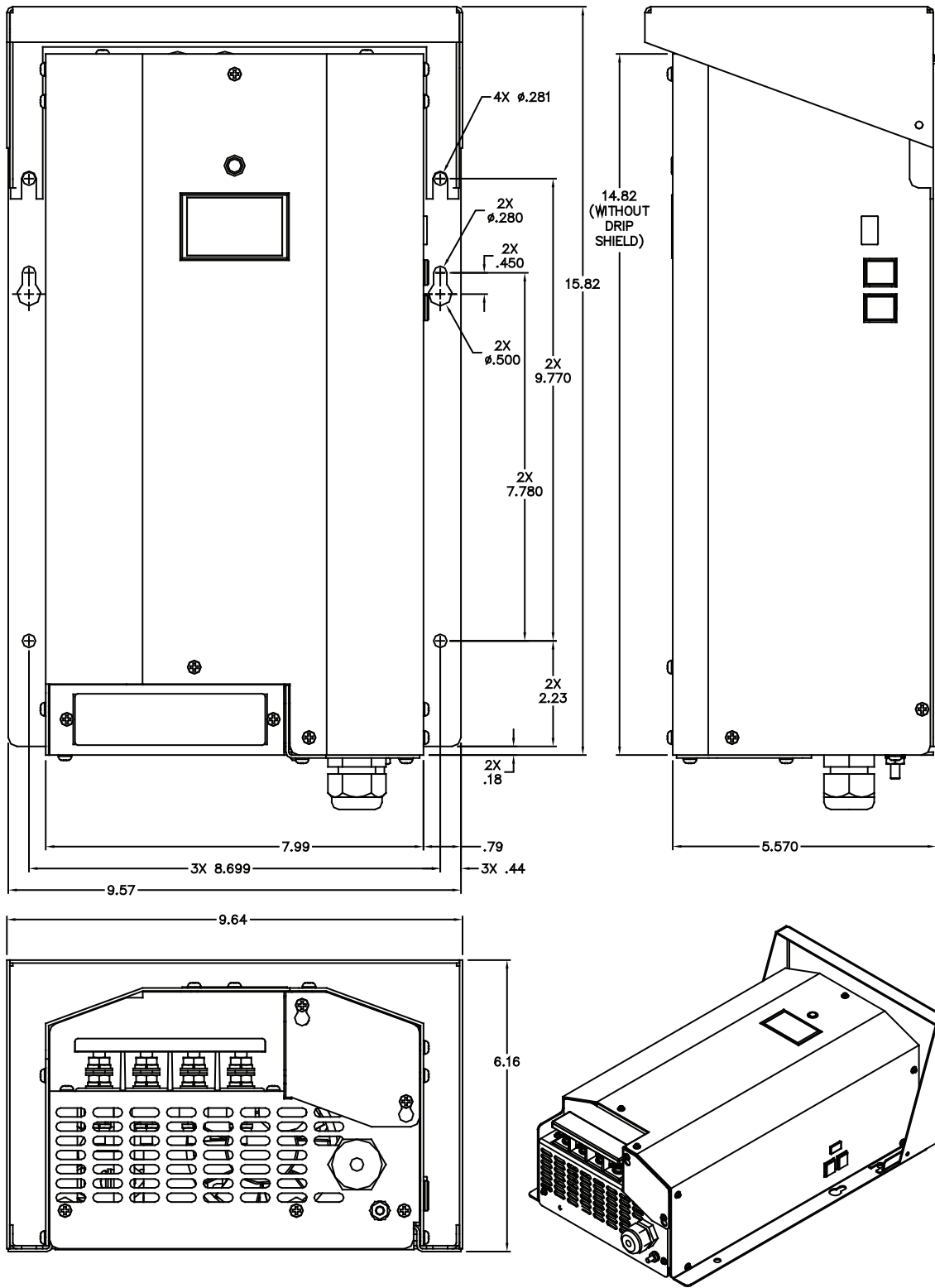

XI) UNIT DIMENSION DRAWING

Model: PT-24-95U

